

SOLIDA 8 PL



Solida 8 PL: 8075740
Kit pellet 200: 8075910
Kit pellet 300: 8075911
Kit pellet 500: 8075912

CERTIFICAZIONE
DEL SISTEMA DI
QUALITA' AZIENDALE



 **sime**[®]

INDEX

1 OPERATION WITH WOOD AND CARBON

| | | |
|-----|---------------------------|----|
| 1.1 | DESCRIPTION | 72 |
| 1.2 | INSTALLATION | 73 |
| 1.3 | USE AND MAINTENANCE | 76 |

2 OPERATION WITH PELLETS AND SPECIAL KIT

| | | |
|-----|---------------------------|----|
| 2.1 | DESCRIPTION | 77 |
| 2.2 | INSTALLATION | 78 |
| 2.3 | USE AND MAINTENANCE | 84 |



1 OPERATION WOOD AND CARBON



1.1 DESCRIPTION

1.1.1 INTRODUCTION

The cast iron "SOLIDA 8 PL" boilers are a valid solution for the present energetic problems, since they can run with solid fuels: wood and carbon.

"SOLIDA 8 PL" boilers conform to Directive PED 97/23/CEE.

1.1.2 SUPPLY

The boilers are supplied in three separate parcels:

- Boiler body assembled and equipped with loading port, ash boxes port, smoke chamber with blast gate damper, ash collection basin and thermostatic draught regulator. Bag containing: 2 handles for the ports, a screw with bakelite knob for the manual

adjustment of the blast gate damper, a contact spring for the bulb of the thermometer and the M6 lever to be fixed at the blast gate damper. "Test certificate" to be kept with the documents of the boiler. Miscellaneous accessories required to use the boiler with pellets (see Section 2 in the manual).

- Cardboard box for casing with thermometer and documents bag.

1.1.3 DIMENSIONS

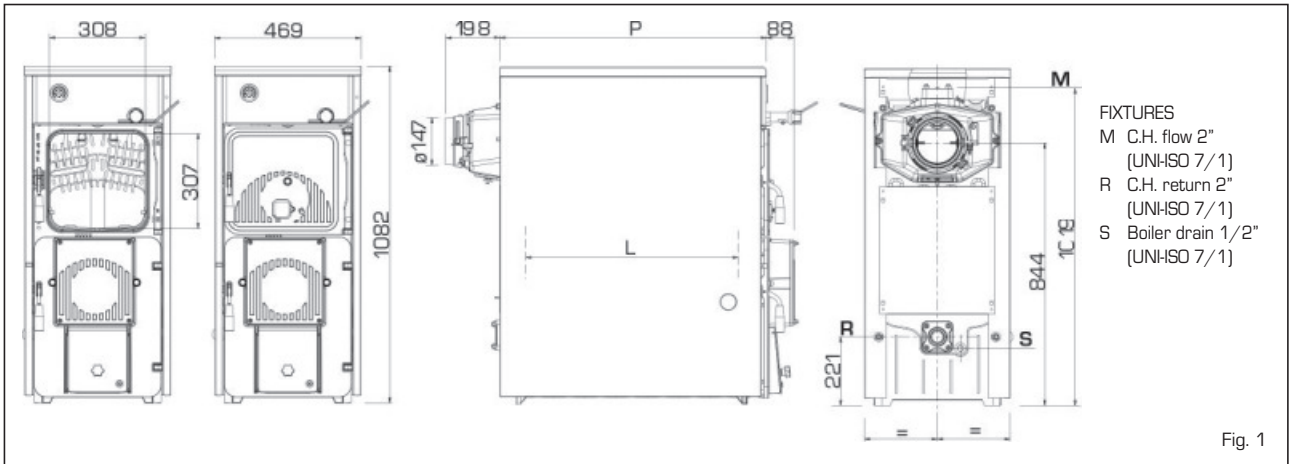

1.1.4 TECHNICAL FEATURES

| Model | SOLIDA 8 PL | |
|---|-----------------|---------------|
| Carbon heat rate* | kW (kcal/h) | 39,5 (34.000) |
| Performance class | | 2 |
| Duration of a coal load | h | ≥ 4 |
| Duration of a wood load | h | ≥ 2 |
| Load volume | dm ³ | 59,5 |
| Minimum chimney depression | mbar | 0,18 |
| P (depth) | mm | 855 |
| L (combustion chamber depth) | mm | 690 |
| Number of elements | n° | 8 |
| Max. operating temperature | °C | 95 |
| Min. temperature of water returned to the plant | °C | 50 |
| Max working pressure | bar | 4 |
| Test pressure | bar | 6 |
| Boiler capacity | l | 43 |
| Weight | kg | 350 |

* The heat rate will be reduced with about 10% for the operation with hard wood (birch - oak - olive).

1.1.5 HEAD LOSSES

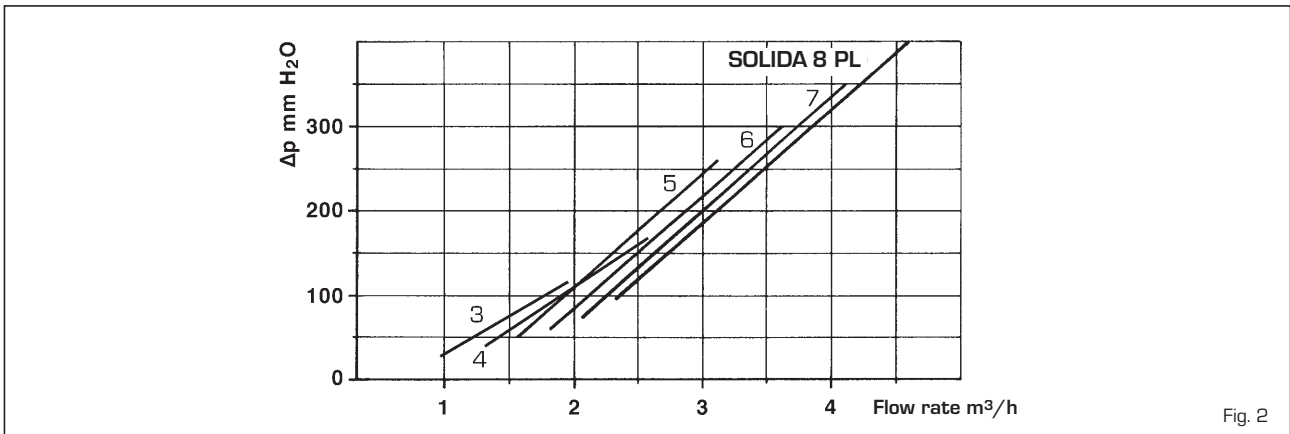

1.2 INSTALLATION

1.2.1 BOILER ROOM

Check that the room has the requirements and features in accordance to the rules in force. Furthermore, the room should be aired, in order to have a regular combustion. Therefore it is necessary to practice some openings in the walls of the room, which correspond to the following requirements:

- They should have a free section of at least 6 cm² for each 1,163 kW (1000 kcal/h). The minimum opening section shouldn't be smaller than 100 cm². The section can also be calculated, using the following ratio:

$$S = \frac{Q}{100}$$

where "S" is expressed in cm².
"Q" is expressed in kcal/h

- The opening should be situated on the lower part of an outer wall, preferably on the opposite of the one for the combustion gas discharge.

1.2.2 CONNECTION TO THE FLUE

A flue should correspond to the following requirements:

- It should be of waterproof material and resistant to temperature of smokes and related condensations.
- It should be of a sufficient mechanical resistance and a weak thermal conductivity.
- It should be perfectly hermetic in order to avoid cooling of the flue.
- It should have the most possible vertical process and the terminal part should have a static aspirator, which assures an efficient and constant discharge of the combustion product.
- In order to avoid the wind creating a very high pressure around the chimneypot, so that it prevails on the ascensional force of the combustion gas, it is necessary that the discharge orifice hangs over at least 0,4 meters of whatever structure adjacent the chimney itself [including the roof ridge] of at least 8 meters.
- The flue shouldn't have a diameter inferior to the boiler connection; for flues with square or rectangular sections, the internal section should be higher than 10% compared to the boiler connection one.
- The net section of the flue can be obtained from the following ratio:

$$S = K \frac{P}{\sqrt{H}}$$

S section resulting in cm²

K reduction coefficient:

- 0,045 for wood
- 0,030 for carbon

P boiler capacity in kcal/h

H height of the chimney in meters

measured from the flame axis at the exhaust of the chimney in the atmosphere. For the dimensioning of the flue you should consider the effective height of the chimney in meters, measured from the flame axis at the top, diminished with:

- 0,50 m for each direction changing of the connection tube between boiler and flue;
- 1,00 m for each horizontal development meter of the connection itself.

1.2.3 CONNECTION OF THE PLANT

The connections should be easily disconnected by means of pipelines with revolving joints. It is always advisable to assemble suitable interception shutters on the piping of the heating installation.

CAUTION: It is obligatory to assemble safety valves on the system not included in supply.

Plant filling

Before starting with the connection of the boiler it is advisable to let the water circulate in the piping, in order to eliminate possible foreign bodies, which could compromise the correct operation of the appliance.

The filling should be carried out slowly in order to make the air bubbles go out through the proper outlets, placed on the heating installation.

The cold loading pressure of the plant and the pre-blowing pressure of the expansion tank, should correspond or however shouldn't be inferior to the height of the static column of the plant in case of closed cir-

cuit heating installations (for example, for a static column of 5 meters, the pre-loading pressure of the tank and the loading pressure of the plant should correspond at least to a minimum value of 0,5 bar).

Features of the feed water

THE TREATMENT OF THE WATER USED FOR THE HEATING INSTALLATION IS ABSOLUTELY NECESSARY IN THE FOLLOWING CASES:

- Very vast plants (with high water contents).
- Frequent replenishment water inlets in the plant.
- If the partial or total emptying of the plant should be necessary.

1.2.4 BRAZIER GRID ASSEMBLY (optional)

In order to carry out the assembly proceed in the following way (fig. 3):

- Punch the card of the outer part, between the front head and the intermediate element, using a bit of 10 ø as indicated in the detail [B].
- Place the back grid [12] in the combustion chamber.
- Place the front grid [10] and block it to the hub [9] with the screws [8] and the nuts [7]; block the front grid from the right side of the boiler body with the screws [5].
- Hook the tie rod [6] to the seats extracted from the front and rear grid.
- Place the intermediate grids [11].
- Introduce the ring [4] and the lever [3] on the hub [9], fixing then everything with the washer [2] and the screw [1].

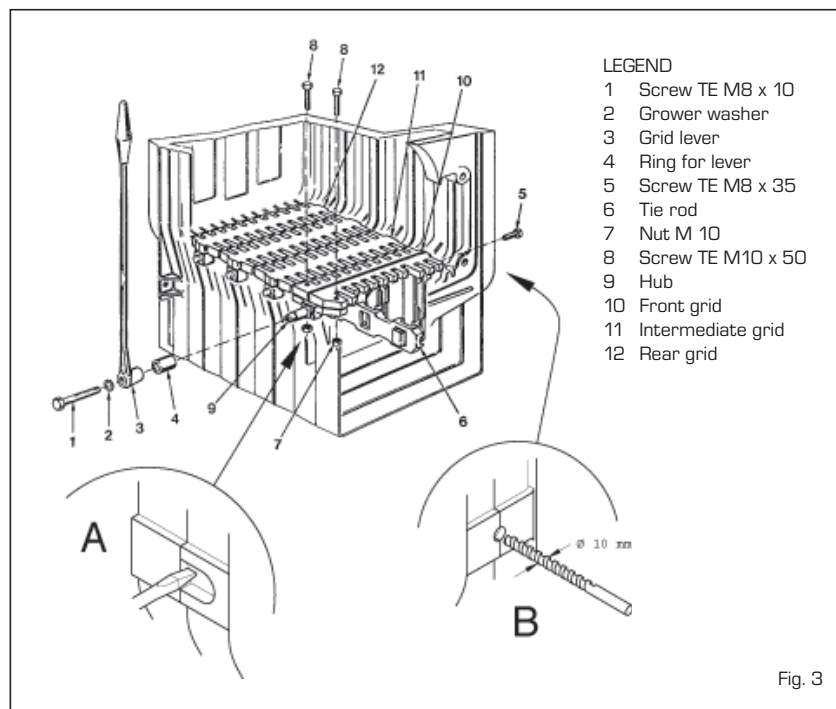

Fig. 3

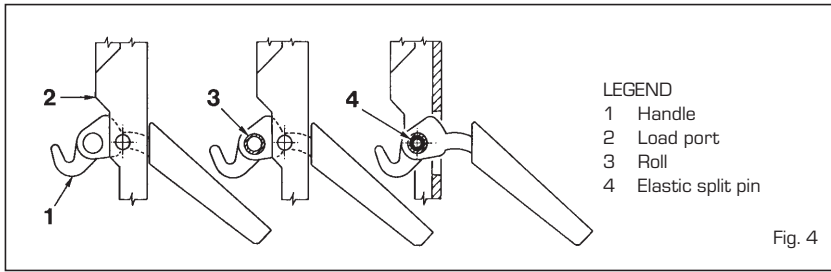

Fig. 4

1.2.5 ASSEMBLY OF THE ACCESSORIES

The closing handles for the ports and the screw with the adjustment knob for the blast gate damper are supplied separately, since they could be damaged during the transport.

Both the handles and the screws with knob are packed in a nylon bag, introduced inside the ash collection basin.

For the assembly of the handles proceed as following (fig. 4):

- Take a handle (1), insert it in the opening of the load port (2) and introduce the roll (3) in the opening of the handle; block the handle introducing the elastic split pin (4).
- Carry out the same operation for the handle of the ash box port.

To assemble the screw with the knob, proceed as follows (fig. 5):

- Remove the screw M8 x 60, which fixes the air blast damper to the ash box port and screw the screw with the bakelite knob (1) on, which is supplied in the packaging.
- Place the blind nut with cap (2) at the end of screw M 10.
- Fix lever M6 to the air blast damper (3) placing it in a horizontal direction on the right. The lever has an opening at its end, where the chainlet of the thermostatic regulator will be connected.

1.2.6 CASING ASSEMBLY

Two superior tie rods are screwed on three nuts at the front side of the boiler: the second and the third nut serve to place correctly the lateral sides of the casing.

Two nuts one to fix the clamp holders for the lateral sides are screwed on the inferior tie rods, both from the front side and from the rear side of the boiler. The assembly of the casing components has to be carried out in the following way (fig. 6):

- Unscrew with some rotations the second or third nut of each tie rod.
- Hook the left side (1) on the lower tie rod and superior of the boiler and adjust the position of the nut and locknut of the upper tie rod.
- Fix the lateral side in blocking the locknut.
- In order to assembly the right side (2) proceed in the same way.
- Hook the front upper board (3) introducing the two splines in the opening, obtai-

ned on each side.

- Carry out the same operation to fix the back lower board (4).

- The protection deflector (5) is fixed to the control board (6) with three self-threading screws.

Fix the board by means of the pressure stakes.

Then unwind the capillary of the thermometer and introduce it in the left sheath of the posterior head, introducing the contact spring.

The right sheath can be needed for the check thermometer:

- Fix the cover (7) at the lateral sides of the boiler.

NOTE: Keep the "Test certification" together with the boiler documents in the combustion chamber.

1.2.7 DRAUGHT REGULATOR

The boilers "SOLIDA 8 PL" can assemble indifferently 2 types of thermostatic regulators.

NOTE: In order to fix the lever with the chainlet in the regulator holder it is necessary to remove the deflector in aluminum,

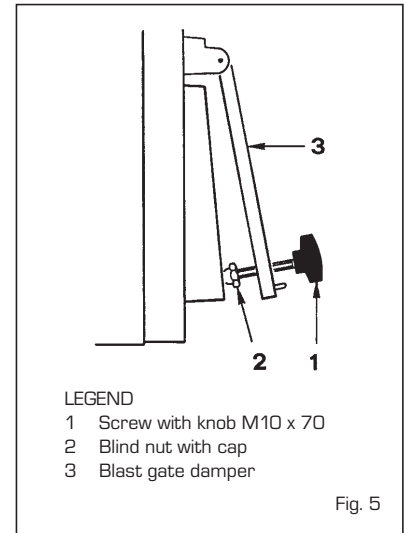

Fig. 5

which is assembled on the control board, by unscrewing the three screws that fix it (fig. 6). Replace the protection deflector after the assembling and related adjustment.

"THERMOMAT RT-C" Regulator

The "Thermomat" regulator is equipped with a thermosetting resin knob of an adjustment field from 30 to 100 °C (fig. 7). Screw the regulator on the 3/4" opening of the anterior head and orientate the red index on the upper part.

The lever with the chainlet should be introduced in the regulator holder after having assembled the instrument holder board and after having removed the plastic lock. If the joint is taken out, which fixes the lever with the chainlet, take care in assembling it

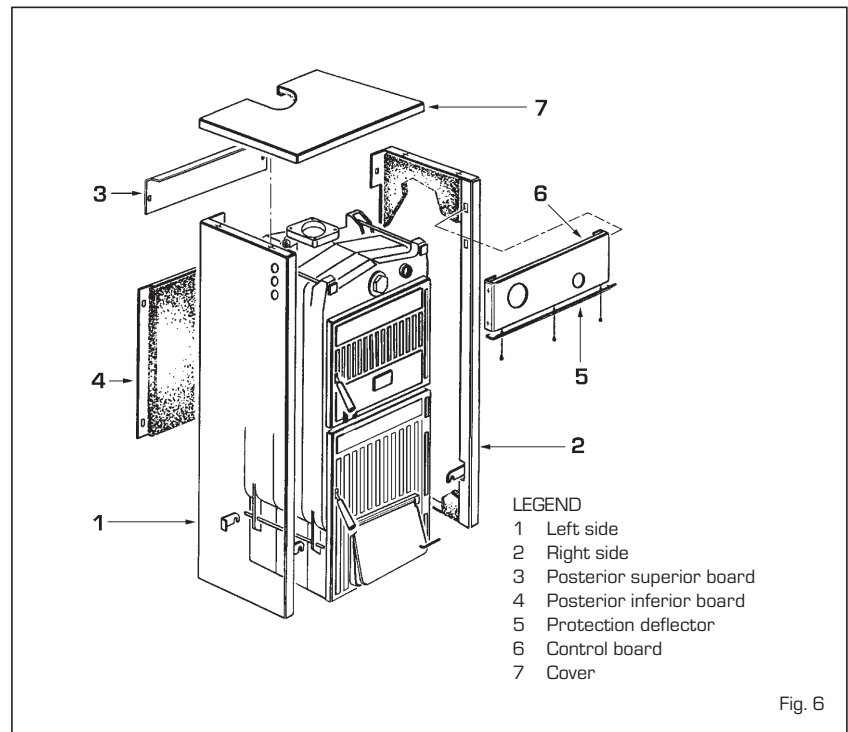

Fig. 6

again in the same position. After having placed the knob at 60°C, block the lever with the chainlet in a slightly inclined position downwards, so that the chainlet will be in axis with the air gate damper.

For the adjustment of the "Thermomat", which essentially consists in the determination of the chainlet length, proceed in the following way:

- Place the knob at 60°C.
- Switch on the boiler with opened air gate damper.
- When the water temperature of 60° C is reached in the boiler, fix the chainlet in such a way on the lever of the air gate damper, in order to obtain an opening of about 1 mm.
- Now the regulator is calibrated and it is possible to choose the desired operating temperature by rotating the knob.

"REGULUS RT2" Regulator

The adjustment field is included between 30 and 90°C (fig. 8).

Follow the same instructions of the "Thermomat" regulator for the assembly and the activation.

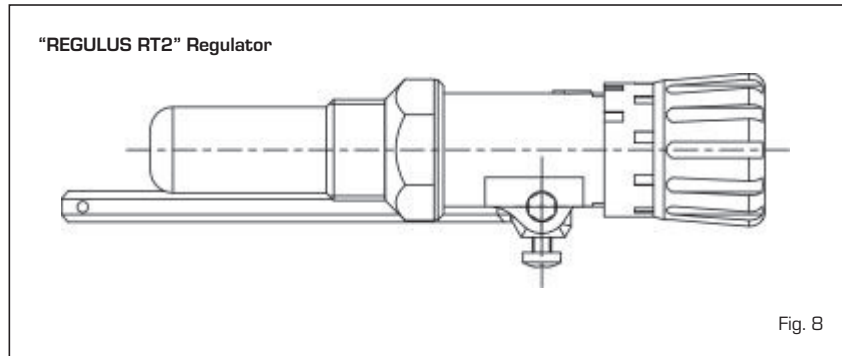
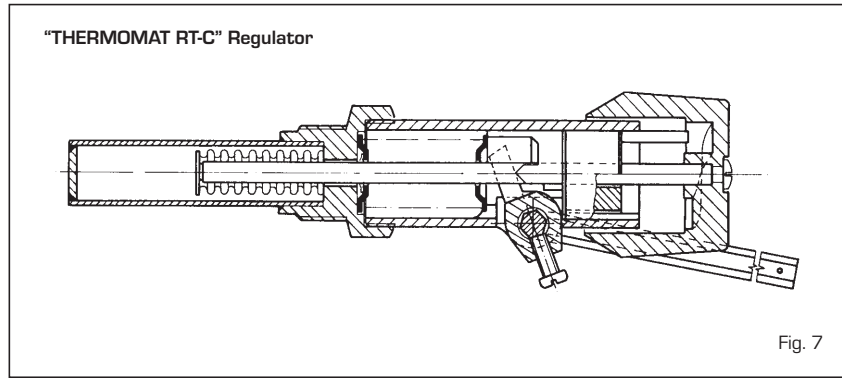

1.2.8 HYDRAULIC CONNECTION DIAGRAM

Open expansion tank system

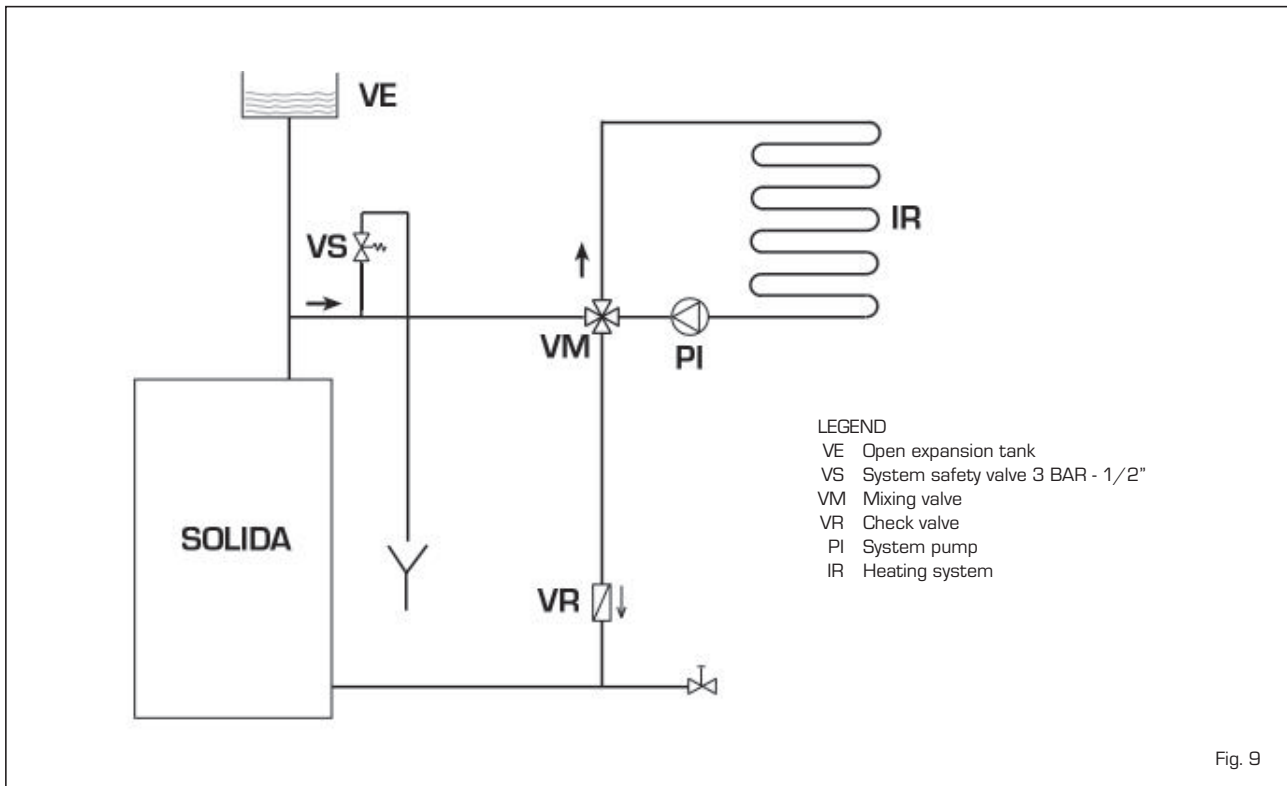

Closed expansion tank system with heat exchanger and optional thermostat valve

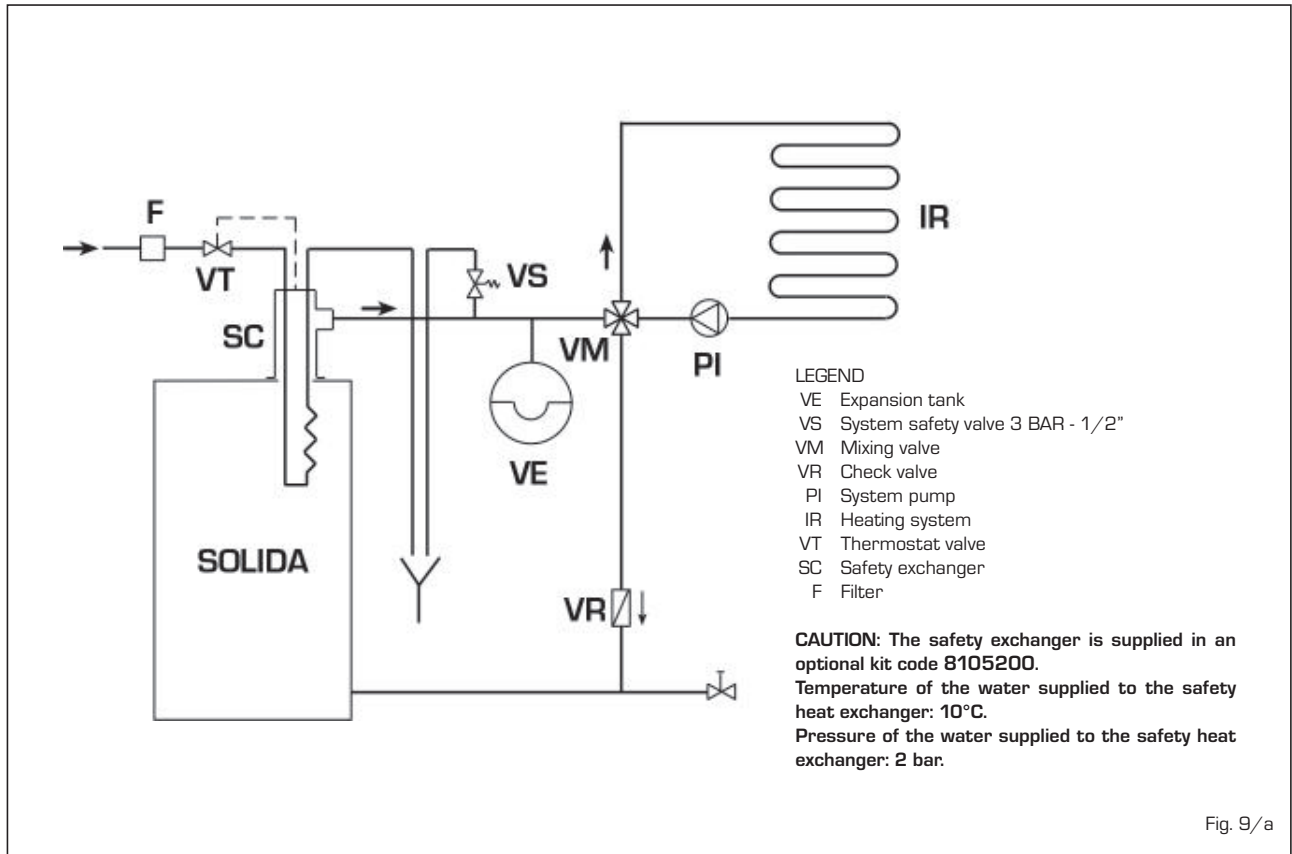

Fig. 9/a

1.3 USE AND MAINTENANCE

1.3.1 PRELIMINARY IGNITION CHECKS

Before the use of the boiler, it is necessary to follow the following instructions:

- The installation where the boiler is connected to, should be preferably with an open expansion tank (fig. 10).
- The tube, which connects the boiler to the expansion tank, should have an adequate diameter according to the norms in force.
- The heating pump should always be running during the operation of the boiler.
- A possible ambient thermostat should never interrupt the pump operation.
- If the installation is equipped with a 3 or 4 ways mixing valve, it should always be placed in the opening position toward the installation.
- Be assure that the draught regulator works regularly and that there aren't impediments, which block the automatic operation of the air gate damper.

1.3.2 CLEANING

The cleaning should be carried out with a certain frequency providing besides the cleaning of the smoke passages, also the cleaning of the ash box, removing the ashes, which are contained in the collection basin. Use a proper pull-through for the cleaning of the smoke passages (fig. 11).

1.3.3 MAINTENANCE

Do not perform any maintenance work, dismantling or removal of parts without properly emptying the boiler first. The boiler must not be emptied when the water is hot.

CAUTION: The safety valve on the system must be inspected by technically qualified personnel in accordance with the laws of the country of distribution and instructions for use of the safety valve. If the system is completely emptied and remains unused for some time, the safety valve must

be inspected before it is used again. If the safety valve should malfunction and cannot be re-calibrated, replace it with a new 1/2" valve calibrated to 3 BAR and conforming with Directive PED 97/23/CEE.

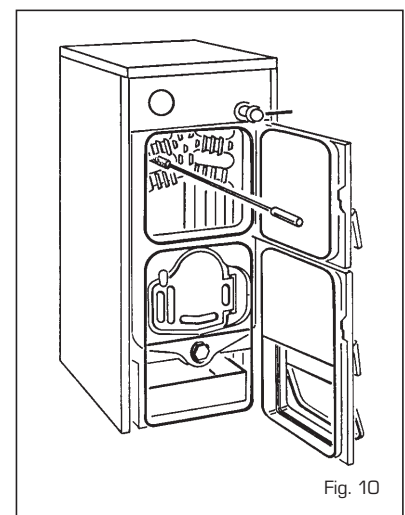

Fig. 10

2 OPERATION WITH PELLETS AND SPECIAL KIT

2.1 DESCRIPTION

2.1.1 INTRODUCTION

SOLIDA 8 PL boilers can be converted in order to be used with pellets.

In this case it is however necessary to separately order the special **Pellet kit 200**

(Code 8075910), **300** (Code 8075911) or **500** (Code 8075912), which includes:

- Two-stage burner.
- Pellet feeder with motor and volute.
- Painted pellet container (with capacities ranging from 200 to 500 dm³).
- Electronic control panel for the automatic burner adjustment.

The burner complies with Class 3 in accordance with EN 303-5.

To obtain an efficient performances, it is advisable to use pellets that have been certified by an authorized body (the characteristics of the pellets used by boiler SOLIDA 8 PL are specified in standard DIN plus).



2.1.2 DIMENSIONS

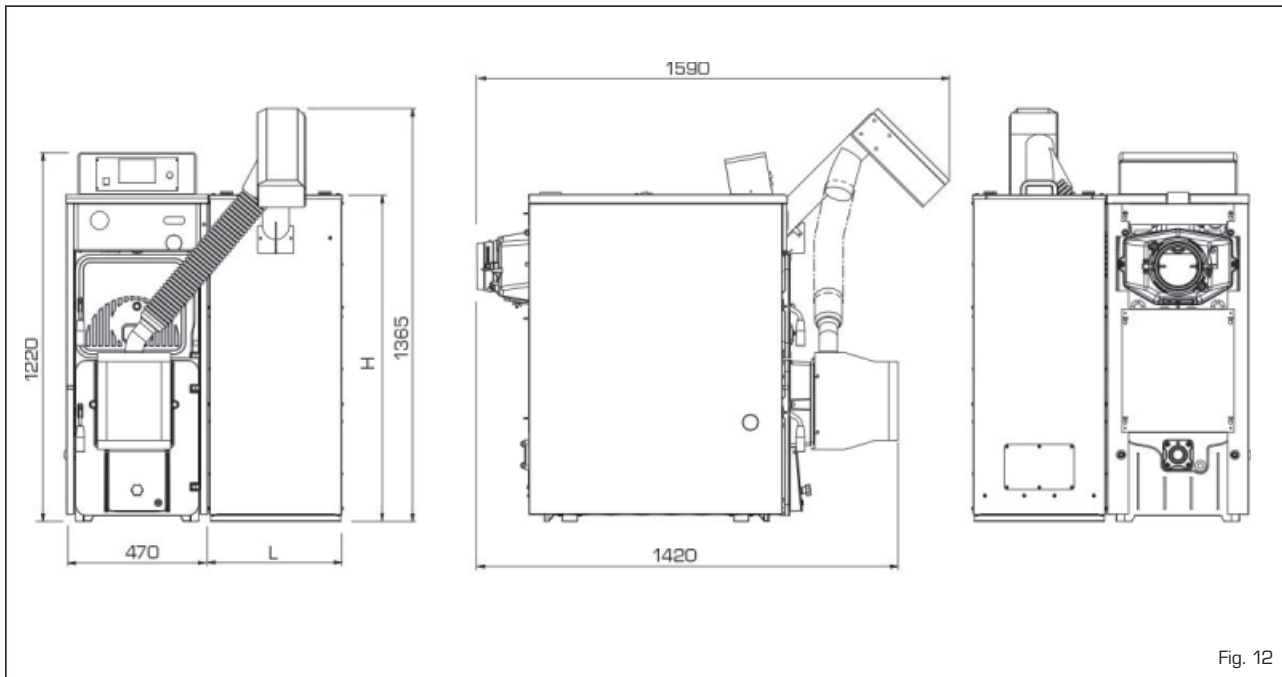

Fig. 12

2.1.3 TECHNICAL FEATURES

| Model | SOLIDA 8 PL | |
|---|-------------|---------|
| Heat output nominal | kW | 26,28 |
| Heat output minimum | kW | 7,88 |
| Heat input nominal | kW | 30,54 |
| Heat input minimum | kW | 9,96 |
| Efficiency maximum | % | 86,0 |
| Efficiency minimum | % | 79,1 |
| Classification of the boiler | | Class 3 |
| CO mg/m ³ to 10% of O ₂ to heat output nominal | | 154,0 |
| CO mg/m ³ to 10% of O ₂ to heat output minimum | | 2114,6 |
| OGC mg/m ³ to 10% of O ₂ to heat output nominal | | 1,7 |
| OGC mg/m ³ to 10% of O ₂ to heat output minimum | | 25,9 |
| G mg/m ³ to 10% of O ₂ to heat output nominal | | 15,11 |
| G mg/m ³ to 10% of O ₂ to heat output minimum | | — |
| Dimensions of the 200 dm ³ pallet container | H | 1081 |
| | L | 440 |
| Dimensions of the 300 dm ³ pallet container | H | 1381 |
| | L | 440 |
| Dimensions of the 500 dm ³ pallet container | H | 1481 |
| | L | 640 |



2.2 INSTALLATION

2.2.1 CONFIGURATION OF THE BOILER FOR THE USE WITH PELLETS AND OPTIONAL KIT

A) Remove the blind flange in cast iron and disassemble the grille, hinge and hake along with the setting screws.



Fig. 13: Disassembly of blind flange

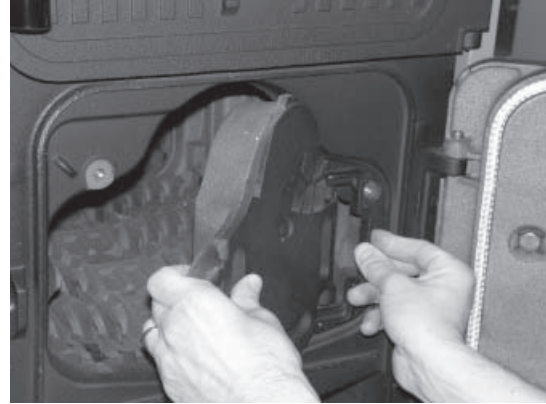

Fig. 13.1: Disassembly of grille

B) Assemble the five baffles supplied, pushing the first deflector against the rear head of the boiler and then the others.

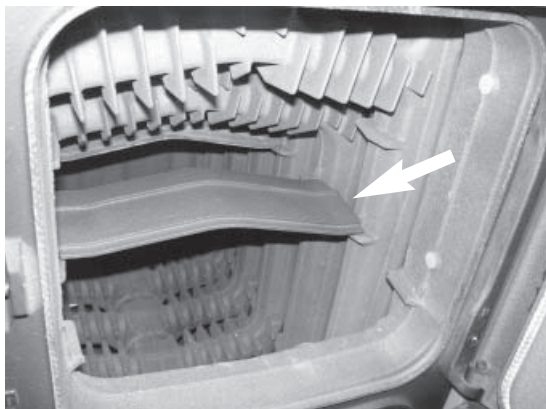

Fig. 13.2: Assembly of baffle

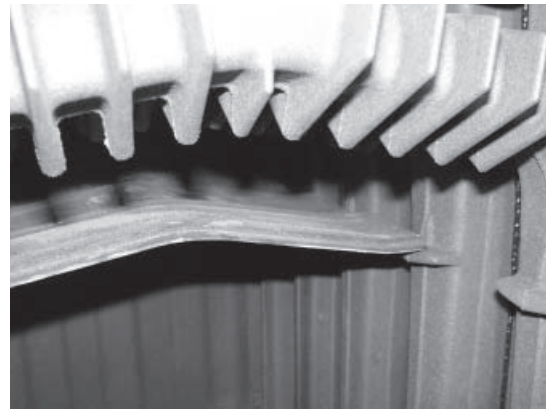

Fig. 13.3: Assembly of baffle

C) Disassemble the boiler thermostatic valve, if present, and close the hole with the cap supplied. Disassemble also the boiler thermometer, if fitted, and close the hole on the front piece with the plastic cap supplied.



Fig. 13.4: Assembly of cap



Fig. 13.5: Closing the front piece

D) Block the inlet port if the boiler has already been used with wood or coal.

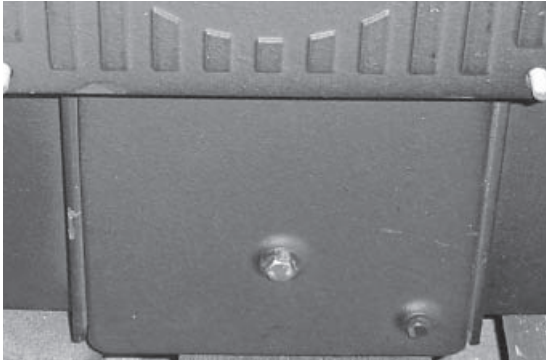

Fig. 13.6: Inlet port

E) Insert the micro pressing pin into the hole on the combustion chamber door and adjust its projection with nut M6.

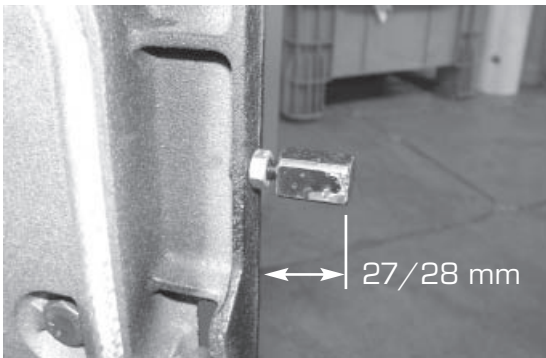

Fig. 13.7: Assembly of micro pressing pin



Fig. 13.8: Pin closing position

F) Insert the hard-wired safety microswitch into the hole on the left side of the mantle. Adjust the projection using the hex jam nuts. Check the operation after assembly.



Fig. 13.9: Assembly of microswitch

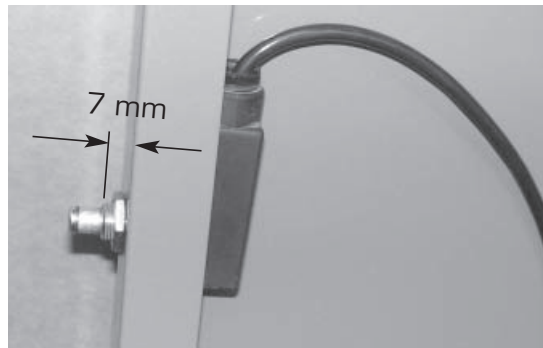

Fig. 13.10: Microswitch position

G) Assemble the two-stage burner fixing it onto the flange by means of the previously disassembled nuts in order to remove the blind flange in cast iron. Assemble the flame baffle.

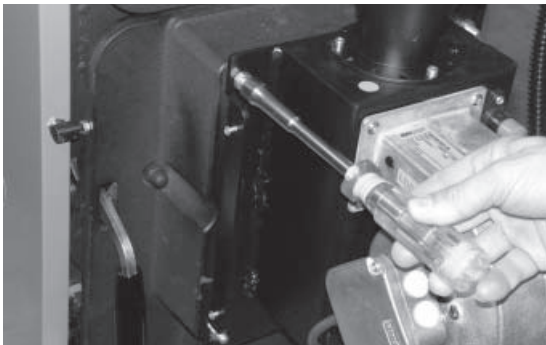

Fig. 13.11: Assembly of burner

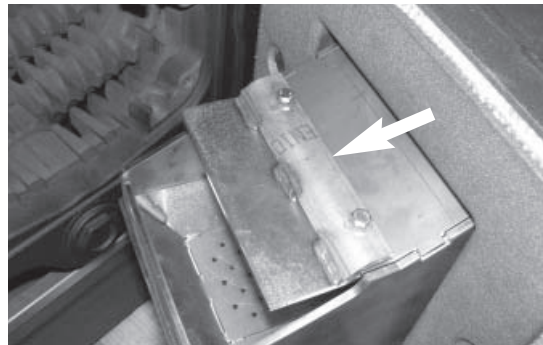

Fig. 13.12: Assembly of flame baffle

H) Assemble the control panel after inserting the probes and the microswitch cable into the hole on the mantle cover. Remove the control panel cover and reassemble the cover after fixing the panel to the cover.



Fig. 13.13: Hole on cover

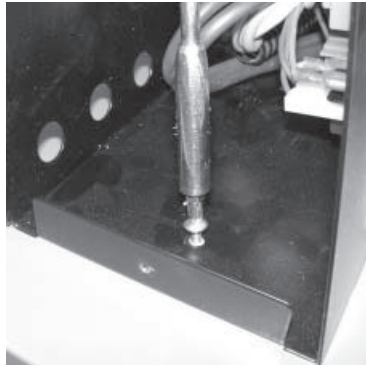

Fig. 13.14: Fixing of control panel

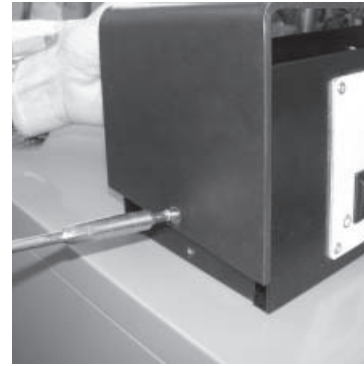

Fig. 13.15: Control panel cover

I) Apply the fiber glass insulation, supplied to protect the cables, on the boiler body. Then, insert the probes into the sleeve on the rear head and connect the micro-switch cable. To protect the micro-switch cable, always verify that it is positioned inside the bend on the side of the mantle. Close the mantle cover.



Fig. 13.16: Insertion of the probes into the sheath



Fig. 13.17: Microswitch wiring

L) Connect the power supply line and plant pump before assembling the cable straps.

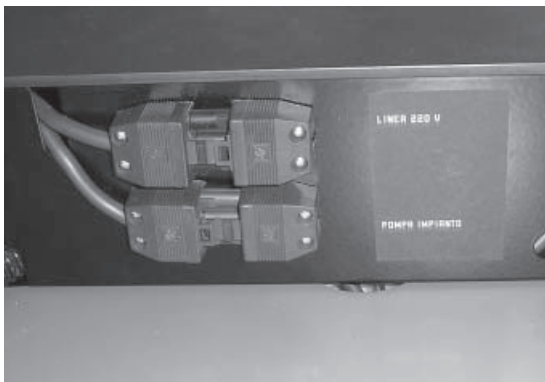

Fig. 13.18: Power supply



Fig. 13.19: Cable straps

M) Assemble the pellet container (with a capacity of 200 - 500 dm³) on the right of the boiler, in support to the boiler and align its front section.

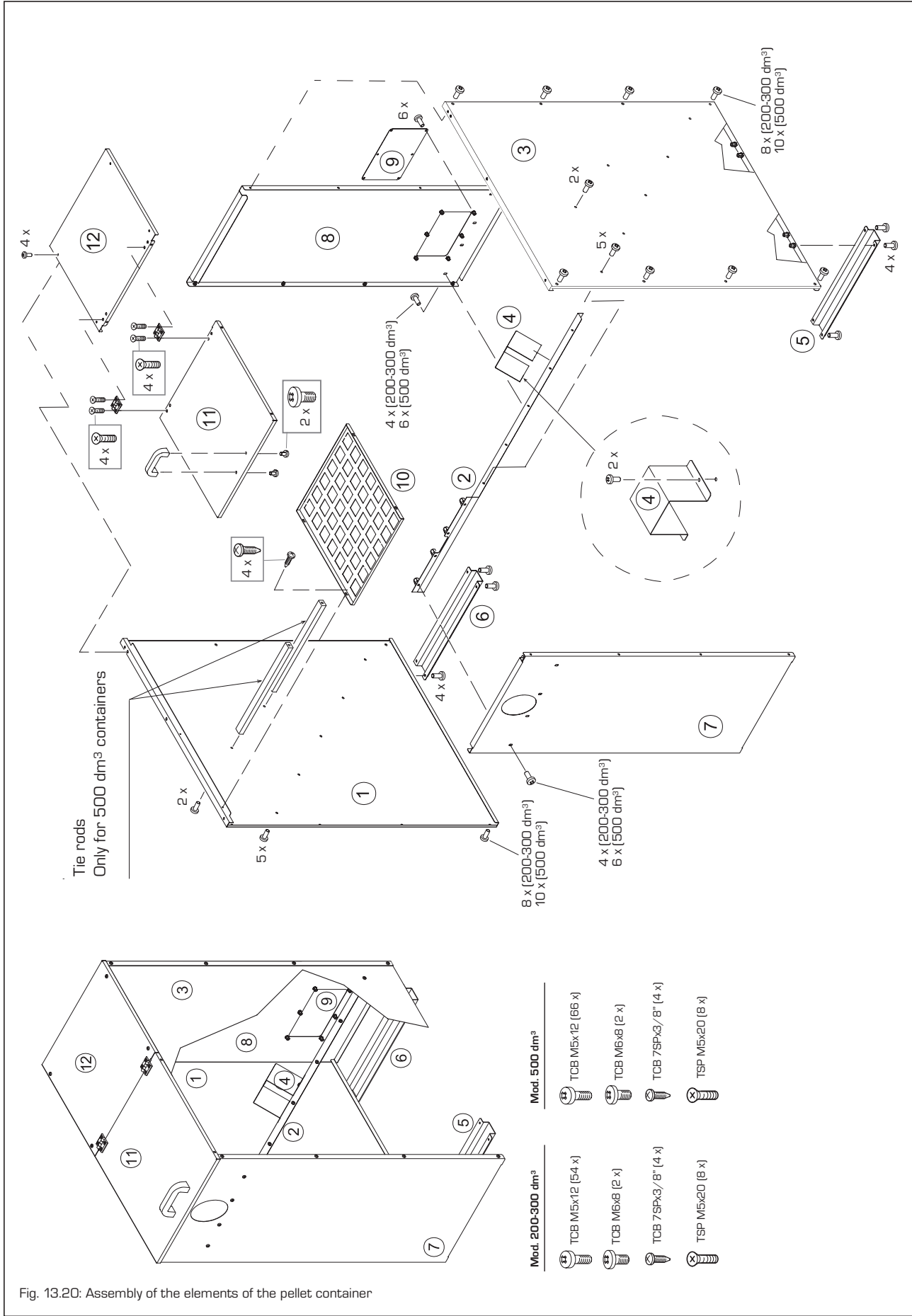

Fig. 13.20: Assembly of the elements of the pellet container

N) Push the feeder volute with the motor into its slot inside the pellet container (with a 200 -500 dm³ capacity) until its stops, and verify that the bucket is pointing upwards. Fix the volute onto the container using the screws that are already available on the container.



Fig. 13.21: Insertion of the volute into the pellet container



Fig. 13.22: Volute fixing

O) Connect the 10 pole connector (JB) on the control panel to the burner, safety sensor and to the volute motor power plug.

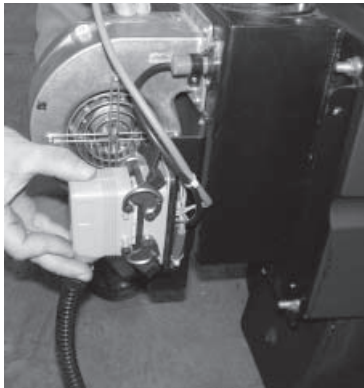

Fig. 13.23: Assembly of connector JB



Fig. 13.24: Connection of sensor

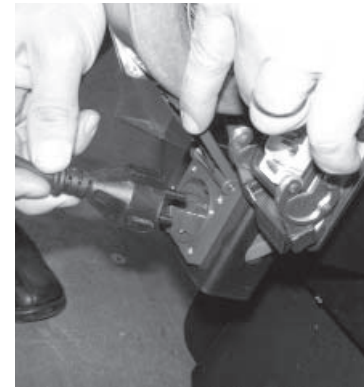

Fig. 13.25: Volute motor plug

P) Assemble the burner motor verifying that it is correctly connected to the safety sensor:



Fig. 13.26: Assembly of burner cover

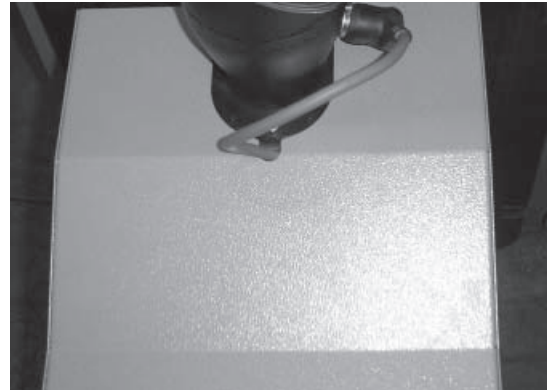

Fig. 13.27: Checking the sensor connection

M) Connect the flexible self-extinguishing pipe with the straps to the burner and pellet feeding volute. Verify that the tube is fully stretched to prevent it from blocking the pellets.

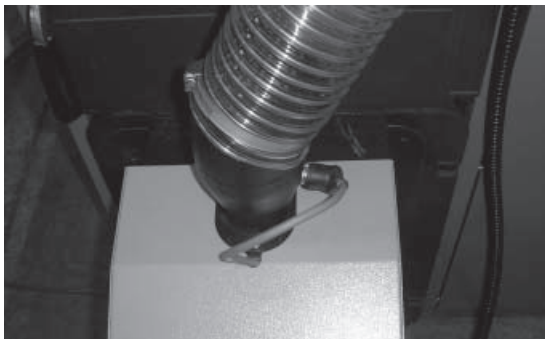
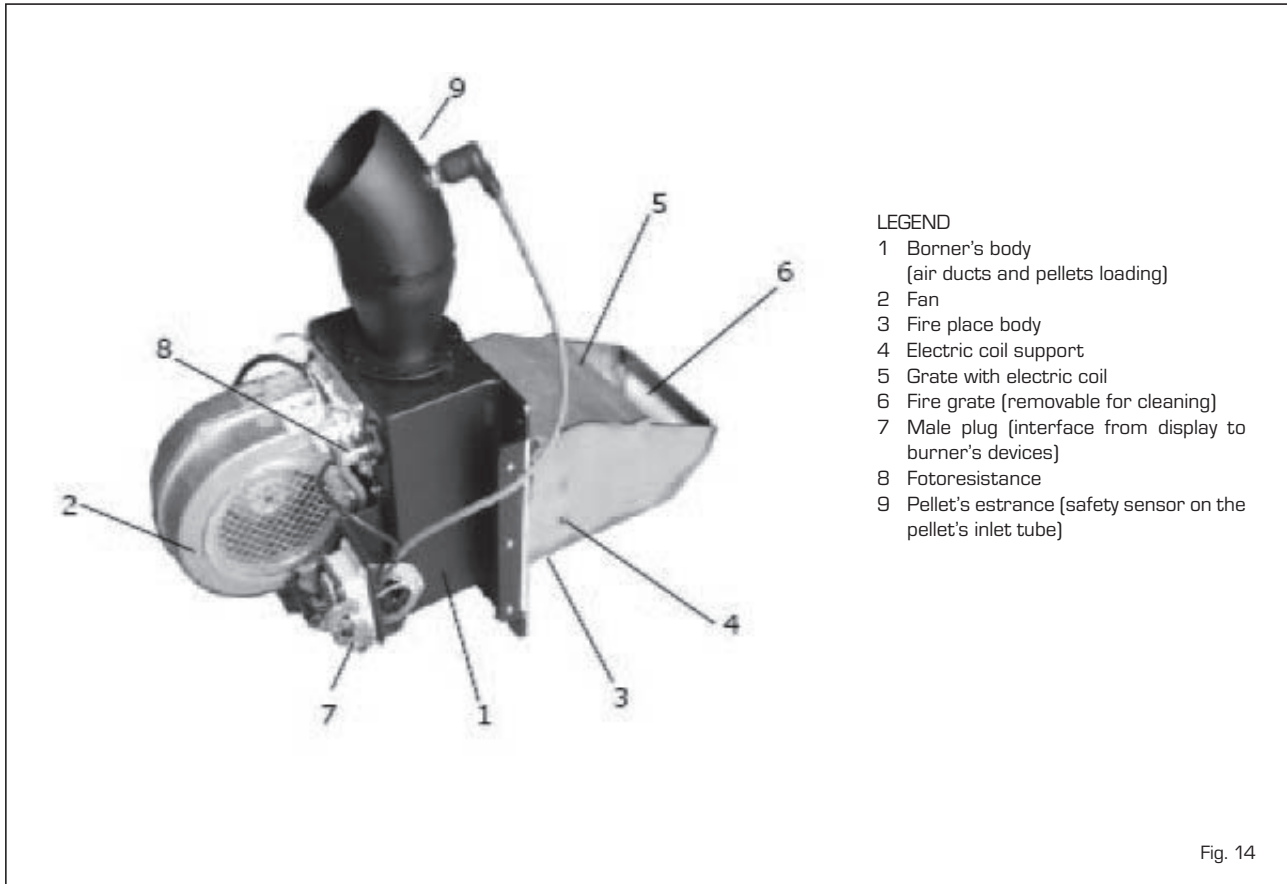

Fig. 13.28: Fixing the lower section of the flexible tube

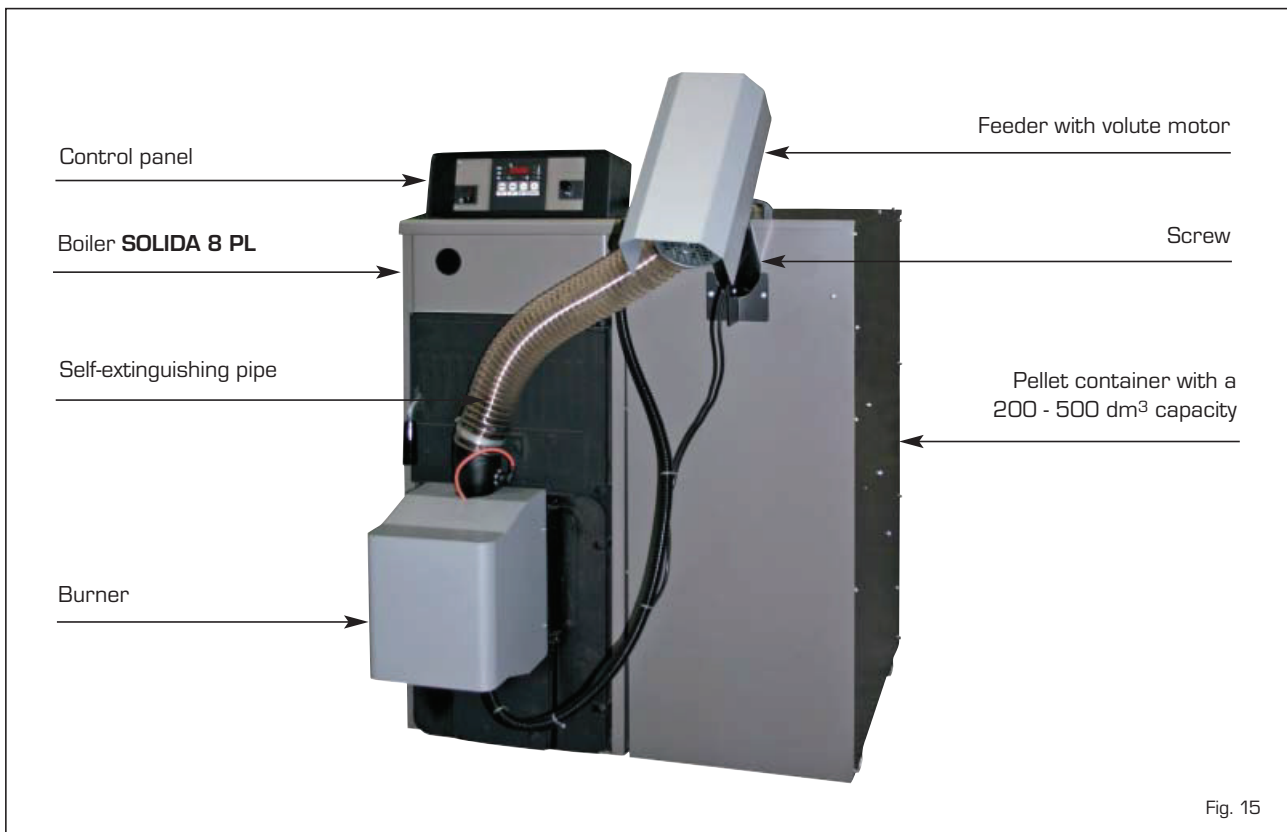

Fig. 13.29: Fixing the upper section of the flexible tube

2.2.2 BURNER'S DESCRIPTION



2.2.3 BOILER AND PELLET CONTAINER ASSEMBLY



2.3 USE AND MAINTENANCE

2.3.1 CONTROL PANEL

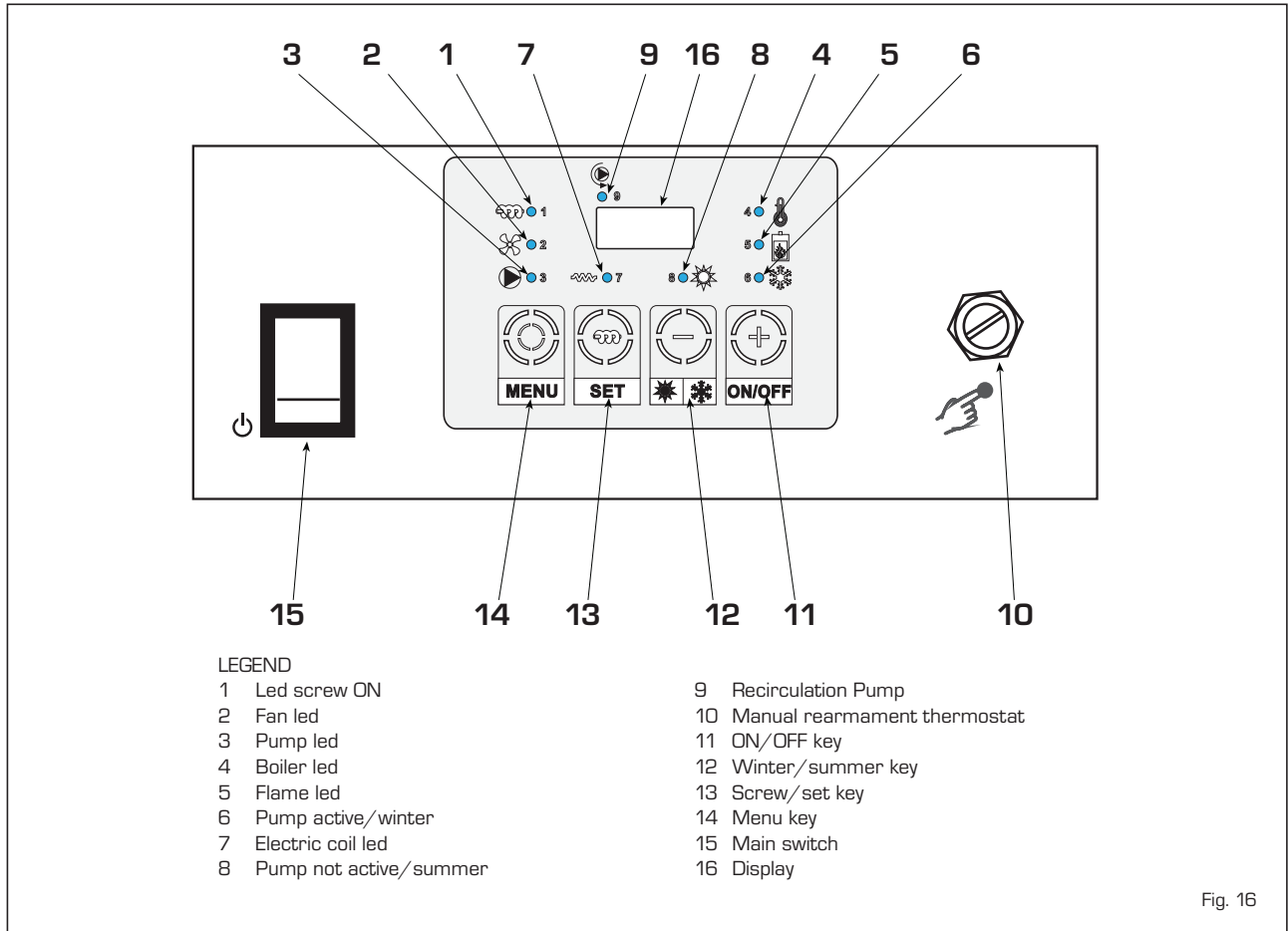

Fig. 16

2.3.2 BUTTONS CONTROL PANEL

| Buttons | | |
|---|---|--|
| Button | 5 sec pressed button | One click function |
| (+) ON/OFF | System ON/System OFF | Into the menu it allows to increase the parameters value |
| (-) ❄️ ❄️ | By pressing it only once it will switch from summer to winter operation and to the contrary | Onto the menu it allows to decrease the parameters value |
| SET | <p>By pressing the key it's possible to manually load the feeding screw. This operation is allowed only when boiler's off. When manual loading is active the display shows "Load". By releasing the key the loading stops. The load has happened when the material begins to come down from the self-extinguishing pipe, to this point to leave endured the push-button.</p> <p>Into the Menu it shows code/value parameters.</p> | |
| MENU | This key allows to regulate boiler's thermostat | |
| <p>NOTE:</p> <ul style="list-style-type: none"> • When the unit is off, by pressing the key ON/+ o quello OFF/- when an alert is shown it's possible to reset alert. If the alert still is active, the display shows it again. • During the setting of the system it's, the display may shows the current flame luminosity. <ul style="list-style-type: none"> - By pressing in the same time keys + and - 5 sec, the display will shows the flame luminosity. - The data will be shown for 5 sec and the display shows the current data again. | | |

2.3.3 LED CONTROL PANEL



| LED's | | | |
|-------------------------------|--|--|---|
| Description | On | Flashing | Off |
| LED 1 Screw | Feeding screw on | - | Fellin screw off |
| LED 2 Fan | Fan on | - | Fan off |
| LED 3 Pump | System pump on | System pump set off by room thermostat | System pump off |
| LED 4 Boiler | Boiler's temperature lower than "boiler thermostat - delta modulation" | Burner's modulating | Temperature higher than "boiler's thermostat" |
| LED 5 Flame | Flame luminosity readed | Burner's on blowing - out phase | Flame luminosity not readed |
| LED 6 Winter | System pump activated | - | System pump not activated |
| LED 7 Electric coil | Ignition coil on | - | Ignition coil off |
| LED 8 Summer | System pump not activated | | System pump activated |
| LED 9 Recirculation | Recirculation pump active | - | Recirculation pump not active |

2.3.4 DISPLAY CONTROL PANEL

| DISPLAY MESSAGES | |
|---|---|
| Temperatura/State/Alarm | |
| The 3 digit display shows the water temperature in the boiler, the state of the system and the possible alarms. | |
| OFF | Off |
| Chc | Check up |
| Acc | Ignition |
| Accr | Repeated ignition |
| StAb | Stabilization |
| nor | Normal |
| rEc | Ignition recovering |
| Mod1 | Modulation 1 |
| Mod2 | Modulation 2 |
| MAnt | Stand - by from boiler temperature |
| Puff | Stand - by from Pu thermostat |
| Sic | Safety |
| Spe | On put out |
| ALt | Allarm present |
| In case any error occurs, taking the boiler to the blowing - out, the display shows an alternance of the messages " Alt " - " Spe " (indicating the boiler's blow-out), the error cause and the boiler's temperature. The shown messages are the following: | |
| TSic | Action of the manual rearmament safety thermostat on boiler's temperature |
| TPEL | Action of the manual rearmament safety thermostat. On pellet's inlet tube |
| tChi | Overheating error readed by the e-board |
| AccF | Ignition failed |
| SPAc | Occasional blowing - out |
| Sond | Probe reading out of range |

See Cap 2.3.8 troubleshooting and fixes

2.3.5 MENU

The parameters of the regulator are programmable by using the menu.

Three menu levels are at disposal: **user menu1**, **user menu2** and **protected menu**.

User menu1:

Accessible by pressing menu key on the control panel. It allows to see the set temperature in the boiler, which's value can be changed from a min of 60°C and a max of 85°C, by pressing the keys + and -.

- The data will be automatically recorded after 20 sec. without to touch any key or by pressing again the key **MENU**.

| LED | Sigla | Description | Default value | Minimum value | Maximum value |
|--------|--------------|-------------------|---------------|---------------|---------------|
| Boiler | TH - CALDAIA | Boiler thermostat | 80 °C | 60°C | 88°C |

2.3.6 OPERATION

Introduction

The control panel regulates the working of the unit **SOLIDA 8 PL**, allowing automatic ignition and feeding of the fuel by the screw motor, drawing pellet directly from the container. A photoresistance controls the flame and a sensor controls the water temperature in the boiler. The setting of all the parameters determinates the operation of the system.

These parameters are included in a special menu reserved to qualified personnel.

Operation conditions

Before ignition fill the screw tube with pellet by using the key "set":

A) **Condition off:** display **OFF**.

This condition is reached afther the blowingout phase.

B) **Check-up condition:** display **Chc**.



it cleans the combustion chamber before ignition.

C) **Ignition condition:** display **Acc.**

It is divided in three phases:

1. *Pre-heating of electric coil:* increasing coil temperature before pellet's feeding.
2. *Fixed ignition:* it serves to feed the useful quantity of pellet for the ignition.
3. *Variable ignition:* It serves to start and makes the flame stronger before the passage to the next phases.

D) **Stabilization condition:** display **Stb.**

It serves to adjust the combustion before to get into the normal operation.

E) **Normal operation:** display shows boiler's temperature.

This phase is active after stb condition.

F) **Modulation condition:** display **Mod.**

This phase serves to reduce the power of the burner before to reach the set boiler's temperature TH-CALDAIA. Default of delta-mod is set on 5°C.

G) **Maintenance condition:** display **MAN.**

This phase is active when the boiler's temperature is higher than "th-caldaia" and it is divided in three phases:

1. *Blowing - out:* it serves to blow out the flame and to decrease the residual heat till the flame luminosity is lower than th-off.
2. *Final - cleaning:* it serves to clean - up the fire grate.
3. *Maintenance:* waiting phase of the system.

H) **Ignition recovering:** display **Rec.**

This phase is active when ignition is interrupted.

I) **Safety operation:** display **Sic.**

It signals and controls safety conditions of the system.

L) **Blowing - out condition:** display **SPE.**

It enables when you manually switch the boiler off or if an alarm occurs (automatic shutdown).

Divided in two phases:

1. *Blowing-out:* it serves to blow-out the flame and to decrease the residual heat till the flame luminosity is lower than the set value TH-OFF.
2. *Final cleaning:* it serves to clean-up the fire grate.

M) **Overtemperature alarm:** display **Alt - tSi.**

This message displays when mechanical thermostat with manual reset feature, located inside the control panel control box, triggers. It electrically interrupts the power supplied to the burner if the temperature of the water inside the boiler reaches 95°C.

As soon as the temperature lowers, it is necessary to reset the thermostat in order to restart the burner, by loosening the cap and pressing the button.

N) **Overtemperature alarm on pellet inlet**

connection: display **Alt - tPE.**

Even the pellet inlet tube is fitted with a contact thermostat, which can be manually reset and that stops the pellet from being fed when the temperature inside the tube reaches 90°C.

O) **Accidental shutdown alarm:** display **Alt-SPA.**

This message displays when there is no fuel in the burner.

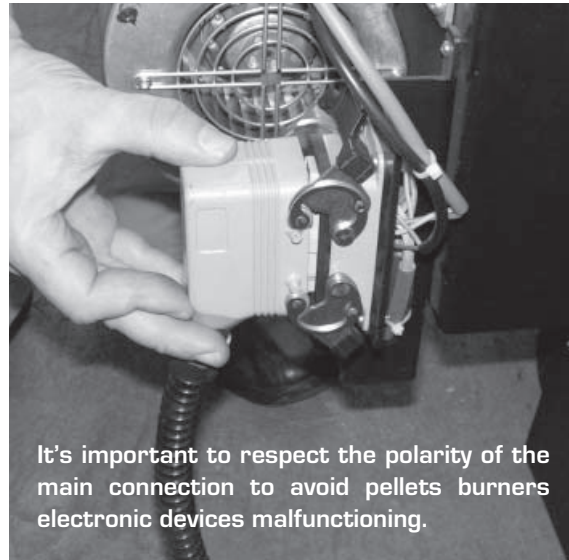
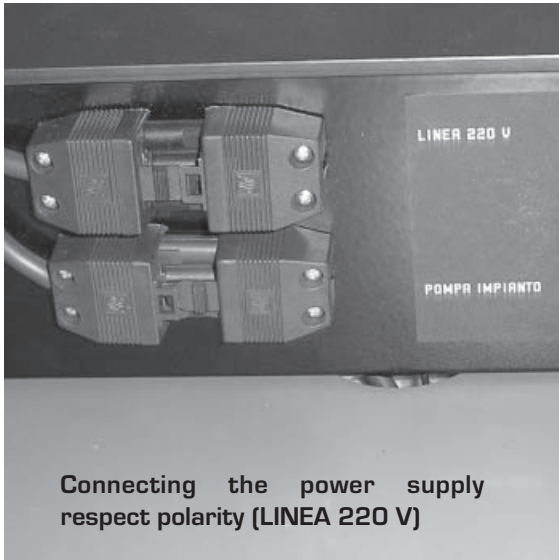

10 POLES CONNECTOR FROM BOILER'S ELECTRONIC PANEL TO THE BURNER (JB)

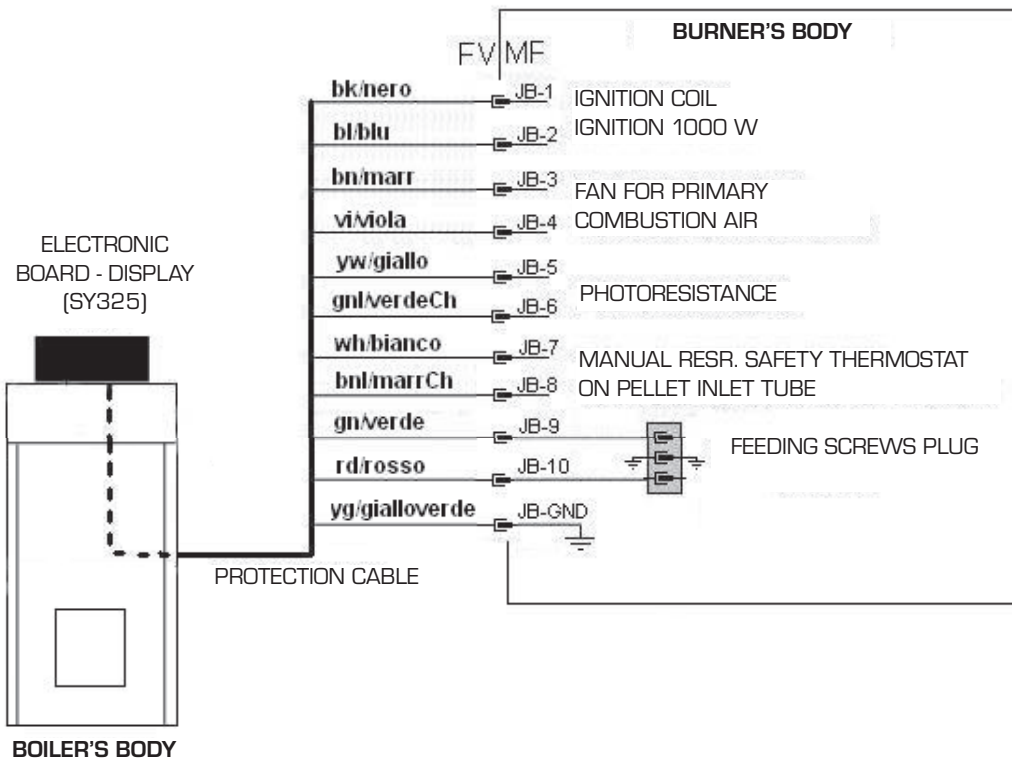

Fig. 17

2.3.8 WIRING DIAGRAM

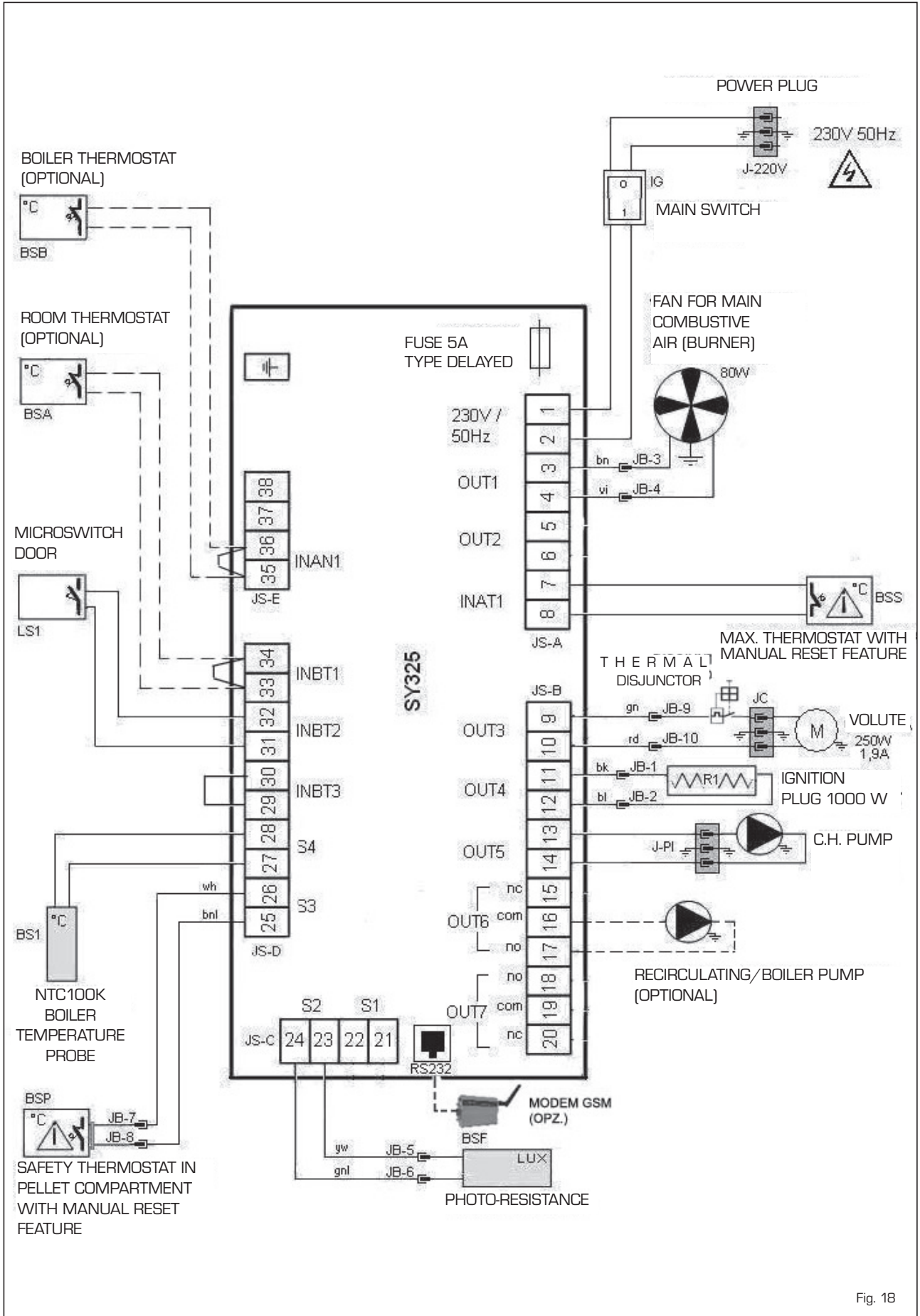

Fig. 18

2.3.9 TROUBLESHOOTING AND CORRECTIVE ACTIONS

Before calling the technical support, take note of the serial number specified on the nameplate of the unit.

Faults are sometimes signaled by a message that provides information on the related cause.

The occurrence of an alarm causes the burner to shutdown (SPE).



| PROBLEM | DISPLAY Alt + | FIX |
|---|------------------|--|
| The burner is blocked | Alt + tSic | The safety thermostat has switched off because the water boiler temperature has exceeded the (pos. 10, fig. 15) and press the reset button, with temperature < 90°C. |
| | | Check the working of the system pump, es. summer function active and boiler temperature set over 80°C. |
| | | System water doesn't circulate well (air inside the system) |
| | | Wrong closing of shutter: |
| The burner was stopped and doesn't restart | Alt + SPAc | Abnormal blow-out: make sure that the pellets charging screw is full of pellets and that the combustible tank is not empty. |
| | | Control than the photoresistor are cleaned in front. |
| | | The thermal disjuncter acts. Press the reset button. |
| The burner was stopped and doesn't restart. Flexible tube full of pellet | Alt + SPAc | Pellet locked in the slide at the bottom of the burner and in the self-extinguishing pipe: <u>low quality pellet</u> . When heated, it tends to stick and to stop flowing. |
| | | Pellet locked in the self-extinguishing pipe. Check that the pipe is well stretched and properly slanting. If necessary, move the pellet container. |
| The burner doesn't start | PUFF | External contact "puffer thermostat" for the remote stop of the burner active. |
| The automatic pellets charging doesn't work (1) | | By the "SET" key when "OFF" is displayed, check the manual running of the screw. |
| | | Check the feeling screw's plung (JC) and the 10 poles connector (JB) are well connected. |
| | | Check that the LED showing the screw operation is on. |
| | | Check if the feeling screw is in the right position. |
| | | Remove sawdust and powder from the button of the pellet's container. |
| | | Check the pellet's way is right. |



| | | |
|--|------------|---|
| The automatic pellets charging doesn't work (2) | Alt + tPEL | The pellet's safety sensor shut-off: remove the connector and make the manual rearmament (it is released at 90°). Check the reason of temperature rising is this position (cleaning, burner full of ash, dirty smoke duct or chimney depression not correct). |
| | | Breakage of the safety sensor on the inlet of the pellet chamber or electric contact of said sensor interrupts along its line to the central unit. |
| | | The thermal disjuncter acts. Press the reset button. |
| Ignition doesn't take place after the second attempt | Alt + ACCF | Check the cleaning of the photocell on the burner on the burner. |
| | | Check the ignition coil is working. |
| | | Check the pellet's quantity loaded for the ignition. Pellet must cover at least 50% of the diagonal grid on the back of the burner's combustion chamber. |
| | | Check the primary fan working. |
| | | Check the cleaning of the burner's grid. |
| | | The thermal disjuncter acts. Press the reset button. |
| The boiler is temporary blocked | Alt + SIC | The electronic coil need a temperature over 95°C. Check the working of the system pump (she is forced in this moment). N.B. the alarm is automatically reset when the boiler's temperature decrease. |
| | | 'Summer' function active and water temp. In the boiler set over 80°C: decrease this set point. |
| | | The system water does 'nt circulate well. Air into the system. |
| In pellet mode the boiler doesn't reach the set temperature and it doesn't keep 60°C | | The size of the boiler is not correct for the system to which it is connected, or the thermal flywheel is too large. Close the system at the start to allow for the thorough warming up of the accumulator. |
| | | Insufficient pellet capacity: - Check the screw position and the capacity - Pellet quality or sizing causing anomalies in the capacity. |
| | | Mixing valve not present into the heating circuit |
| The main switch's les is 'on' but the elboard doesn't start. | | Electronic board's fuse burned-off:exange it with a fuse of the same Ampere type delayed. |
| The main switch does't light on | | Check the 220V electricity feeding and the connection of his plug. |
| | | Broken led. |

| | | |
|--|--|---|
| The system pump doesn't work | | Check if the summer function is active. |
| | | Check the right plug-in. |
| | | The pump can be blocked, burned-off or air into the system. |
| | | Enabling from ambient thermostat missing (or the bridging on the plug - in case the thermostat is not available - is missing - in this case the pump led is flashing). |
| The burner get dirty very quickly | | <u>Low quality pellet</u> (too dusty pellet or excess of bark and of mineral residuals, hampering the, automatic removal during the cleaning). |
| | | Underpressure is not enough. |
| | | Pellet's diameter \neq 6mm. |
| Smokes loss (pellet mode) | | Check the right closing of the front doors and of the top cover. |
| | | Check the burner's seal is well fastened to the door. |
| | | Check the right connection between boiler's smokes outlet and the chimney. |
| Pellet stops into the flexible tube | | Check the right position |
| | | Too much sawdust. Clean it. |
| | | Low quality pellet which tends to stick to the coilholder slide thus hampering the descent. |
| Primari fan stop | | Set boiler's temperature is reached (MAnt). |
| | | Boiler's OFF. |
| | | The fan is blocked or broken: contact the nearest service center. |
| | | Door open (Por) (only on boiler's prepared for this). |
| The pellet descent self-extinguishing pipe has melted. | | Action of the safety system (melting of the pipe) to physically separate the pellet storing chamber from the burner in case of back-fire. Always replace the pipe with a self-extinguishing pipe to avoid affecting the safety device described above. |
| | | Underpressure is not enough into the chimney. |
| | | Low quality pellet obstructing the burner. |



2.3.10 CLEANING (FIG. 19)

Cleaning operations must be carried out at regular intervals and only when the boiler is cold.

Combustion residuals collect in the removable drawer that must be emptied before starting the boiler. To remove all combustion residuals, use an ordinary aspirator and verify that all the ashes inside the combustion chamber have been completely removed. The aspirator can also be used to clean the pellet grille.

To clean the fume ducts inside the boiler body, use a wiper.

ATTENTION: if the generator is switched off for long periods of time (above 15 days), it is necessary to empty the 200 - 500 dm³ pellet container in order to prevent the pellets from absorbing excessive humidity, which could affect the operation of the boiler. A high amount of humidity in the pellets could cause them to pulverize, increase the amount of residuals in the brazier and obstruct the pellet feeding system.

2.3.11 ANNUAL MAINTENANCE

For optimum performance, it is advisable to have the boiler inspected accurately and thoroughly by qualified personnel at least once every season.

Before performing maintenance operations, verify that the boiler is cold and has been disconnected from the mains.

2.3.12 THE THERMAL DISJUNCTOR

The auger motor is protected by a single pole thermal disjuncteur (ETA 106-P10-1, 5A) overcurrent small. Safety intervention by means of a quick-release mechanism and interruption of the contact for motor protection.

In the event that the thermal disjuncteur to intervene, to restart the burner reset button shown in Fig. 20.

ATTENTION: The parts numbers of the Unit from 100259 to 100298 included, have the thermal disjuncteur inside the control panel.

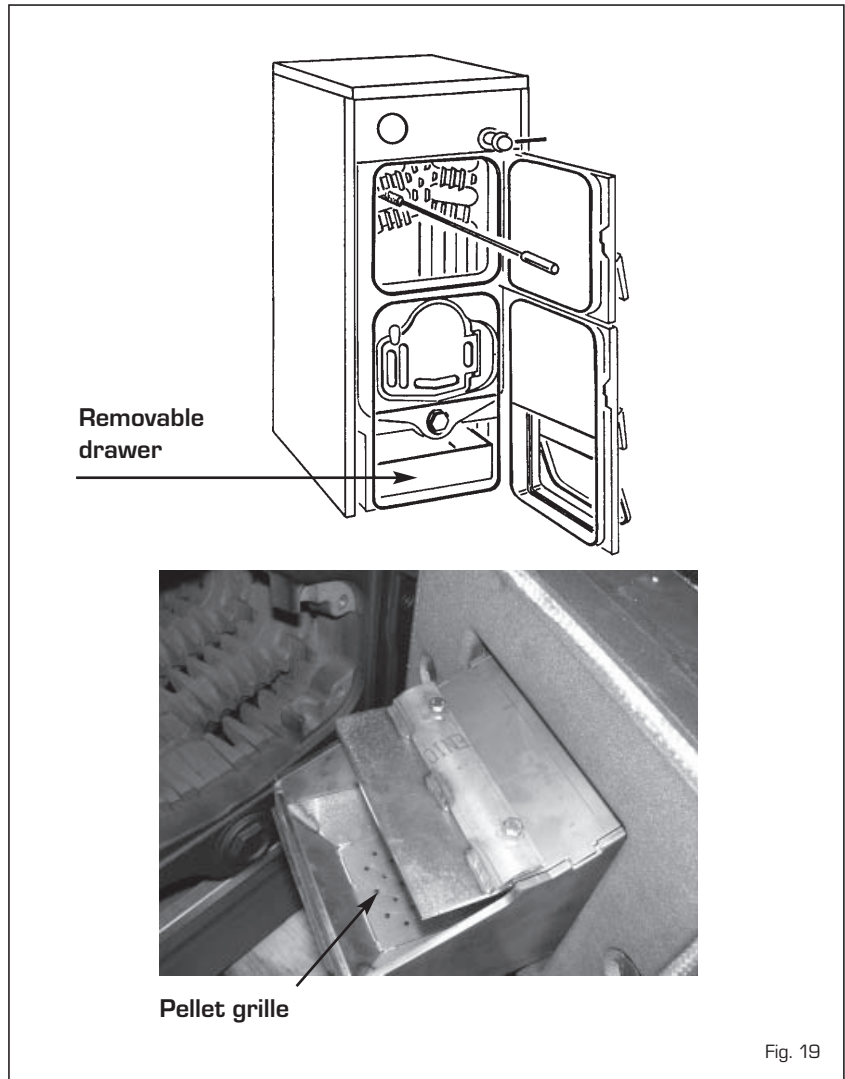

Fig. 19

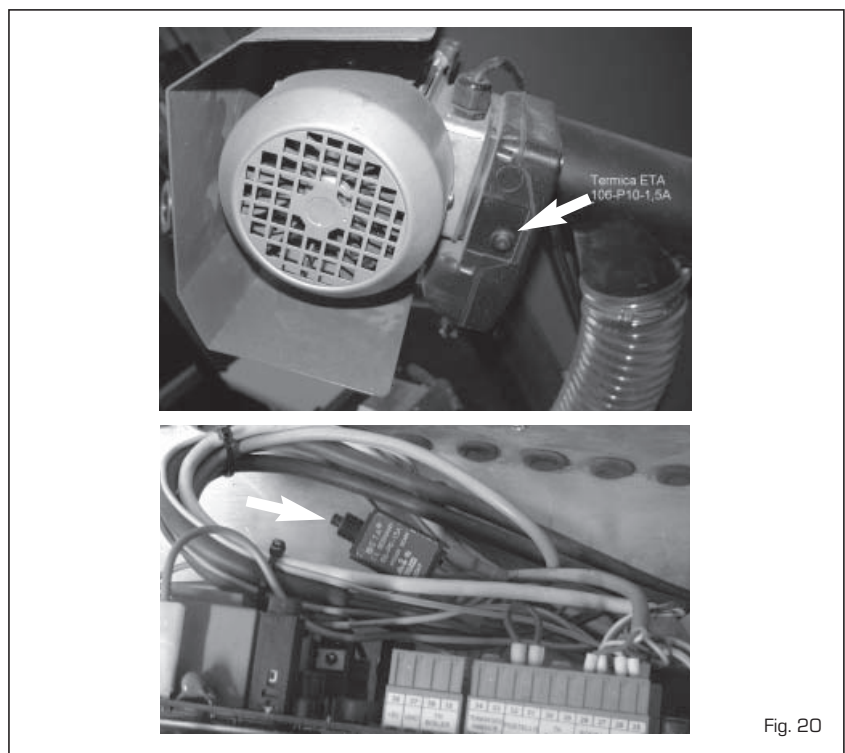

Fig. 20

IT

ES

PT

GB

IT

ES

PT

GB



Fonderie Sime S.p.A - Via Garbo, 27 - 37045 Legnago (Vr)
Tel. + 39 0442 631111 - Fax +39 0442 631292 - www.sime.it