



1R OF - 2R OF/OF S/GT OF



Remove the **“Testing Certificate”** from inside the combustion chamber and keep together with the instructions manual.

The package of the **“2R GT OF”** boiler contains instructions for installation, operation and maintenance of the diesel burner.

The installation technician must fill in the **“Testing Certificate”** completely once the cast iron body of the dismantled boilers has been tested (vers. **“2R OF S”**).

**CHARACTERISTICS OF THE SYSTEM SAFETY VALVE:** calibration pressure: 5 bar; maximum generator power: 373.4 Kw, 3/4” x 1” fixtures (see Caleffi catalogue, code 527550).

## CONTENTS

### 1 BOILER DESCRIPTION

1.1	INTRODUCTION .....	40
1.2	DIMENSIONAL DETAILS	
1.3	TECHNICAL FEATURES	
1.4	LOSS OF HEAD .....	41
1.5	COMBUSTION CHAMBER DIMENSIONS .....	42
1.6	SOME BURNER BRANDS COMPATIBLE	

### 2 INSTALLATION

2.1	BOILER ROOM .....	43
2.2	BOILER ROOM DIMENSIONS	
2.3	CONNECTING UP SYSTEM	
2.4	CONNECTING UP FLUE	
2.5	BOILER BODY ASSEMBLY .....	44
2.6	FITTING THE CASING	
2.7	ELECTRICAL CONNECTION .....	45
2.8	“RVA 43.222” CLIMATE CONTROLLER	

### 3 USE AND MAINTENANCE

3.1	COMMISSIONING THE BOILER .....	48
3.2	LIGHTING AND OPERATION	
3.3	CLEANING THE BOILER	
3.4	USER WARNINGS .....	49
3.5	HOW TO USE THE “RVA 43.222” .....	50

# 1 BOILER DESCRIPTION

## 1.1 INTRODUCTION

The cast iron boilers "1R/2R OF - 2R OF S" for gas-oil or gas has been designed in compliance with the European Directives 2009/142/CEE, 2004/108/CEE, 2006/95/CEE, 92/42/CEE.

The cast iron boilers "2R GT OF" for gas-

oil has been designed in compliance with the European Directive 92/42/CEE.

The components for "1R/2R OF" installation are supplied in three separate packages: boiler body with smoke chamber dismantled and inserted in the combustion chamber, casing with enclosed documents and control

panel.

Instead, the boilers "2R OF S" are supplied with the dismantled boiler body.

The boilers "2R GT OF" are supplied in four separate packages, as they come with a gas oil burner and relating instructions.

## 1.2 DIMENSIONAL DETAILS

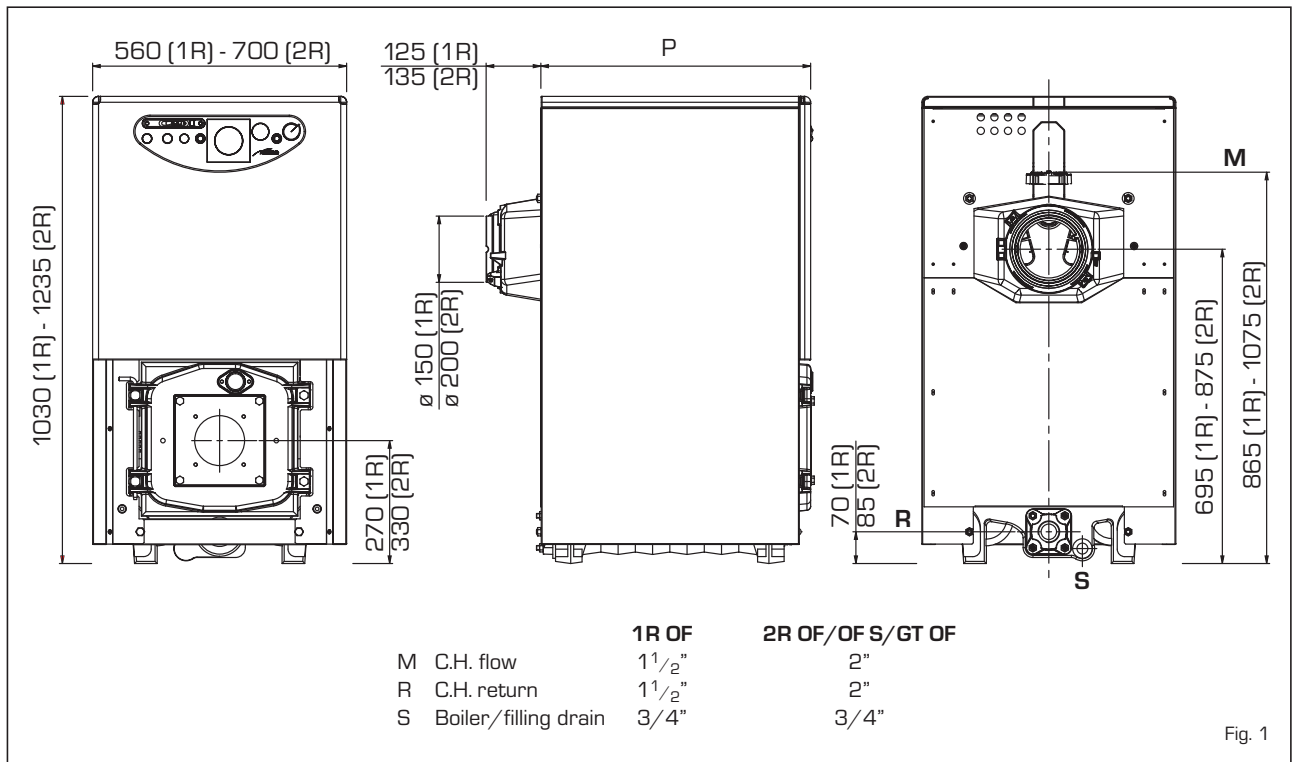

## 1.3 TECHNICAL FEATURES

### 1.3.1 "1R OF" boiler

		6	7	8	9	10
<b>Output</b>	kW	64.8	74.0	84.0	93.3	102.1
	kcal/h	55,700	63,600	72,200	80,200	87,800
<b>Input</b>	kW	73.4	83.1	93.8	103.4	113.5
	kcal/h	63,100	71,500	80,700	88,900	97,600
<b>P (depth)</b>	mm	595	670	750	825	900
<b>Sections</b>	n°	6	7	8	9	10
<b>Maximum water head</b>	bar	4	4	4	4	4
<b>Water content</b>	l	375	42.0	46.5	51.0	55.5
<b>Loss of head smoke</b>	mbar	0.20	0.16*	0.22*	0.30*	0.35*
<b>Comb. chamber pressure</b>	mbar	- 0.01	0.06	0.08	0.08	0.10
<b>Suggested chimney depression</b>	mbar	0.21	0.22	0.30	0.38	0.32
<b>Smokes temperature</b>	°C	225	217	209	201	192
<b>Smokes flow</b>	m <sup>3</sup> n/h	68.0	77.7	88.0	97.6	107.5
<b>Adjustment range</b>						
Heating	°C	30÷85	30÷85	30÷85	30÷85	30÷85
<b>Smokes volume</b>	dm <sup>3</sup>	42	46	50	55	60
<b>Weight</b>	kg	261	293	325	357	389

\* Without baffles

### 1.3.2 "2R OF/OF S/GT OF" boiler

		6	7	8	9	10	11	12	13	14	15
<b>Output</b>	kW	100.6	123.8	147.1	165.1	179.7	197.7	213.4	230.2	248.8	266.9
	kcal/h	86,500	106,500	126,500	142,000	154,500	170,000	183,500	198,000	214,000	229,500
<b>Input</b>	kW	113.5	139.1	164.7	184.1	199.7	219.7	237.1	255.8	276.4	296.7
	kcal/h	97,600	119,700	141,600	158,300	171,700	188,900	203,900	220,000	237,700	255,200
<b>P (depth)</b>	mm	735	835	935	1,035	1,135	1,235	1,335	1,435	1,535	1,635
<b>Sections</b>	n°	6	7	8	9	10	11	12	13	14	15
<b>Max. water head</b>	bar	5	5	5	5	5	5	5	5	5	5
<b>Water content</b>	l	92	107	122	136	151	165	180	194	209	223
<b>Loss of head smoke</b>	mbar	0.10	0.15	0.22	0.29	0.24*	0.37*	0.39*	0.42*	0.49*	0.50*
<b>Comb. chamb. press.</b>	mbar	- 0.02	- 0.02	- 0.01	- 0.02	- 0.02	- 0.01	- 0.02	0.31	0.35	0.50
<b>Suggested chimney depress.</b>	mbar	0,12	0,17	0,23	0,31	0,26	0,38	0,41	0,73	0,84	1,00
<b>Smokes temperature</b>	°C	238	236	234	232	229	224	219	215	211	207
<b>Smokes flow</b>	m <sup>3</sup> /h	105.2	129.2	153.3	171.9	186.9	205.4	221.6	238.9	257.9	276.6
<b>Adjustment range</b>											
Heating	°C	30÷85	30÷85	30÷85	30÷85	30÷85	30÷85	30÷85	30÷85	30÷85	30÷85
<b>Smoke volume</b>	dm <sup>3</sup>	83	92	101	110	119	128	138	147	157	167
<b>Weight</b>	kg	462	520	578	636	676	734	792	850	908	966

\* Without baffles

### 1.4 LOSS OF HEAD

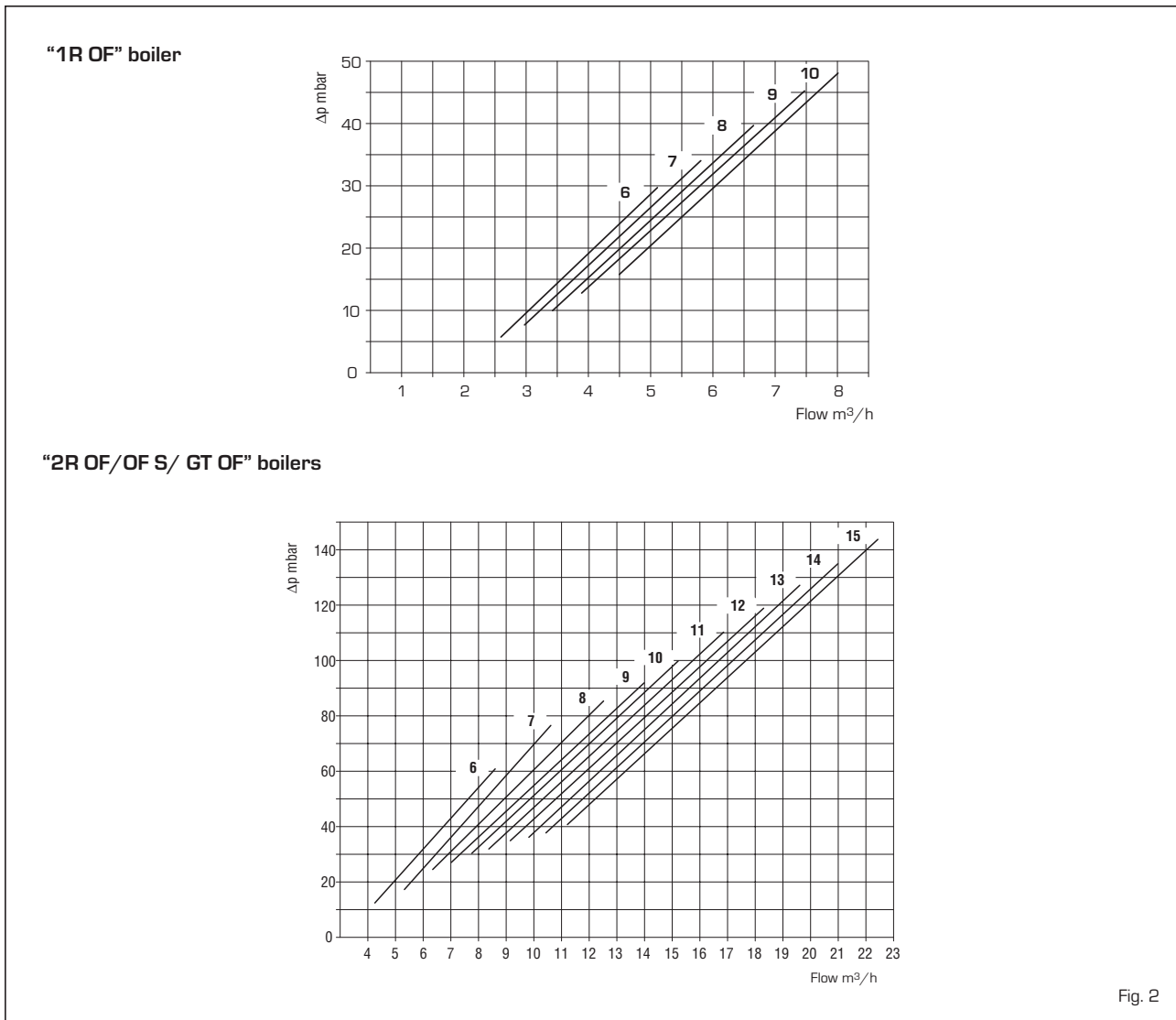

Fig. 2

## 1.5 COMBUSTION CHAMBER DIMENSIONS

The dimensions of this direct passage combustion chamber are reported in fig. 3.

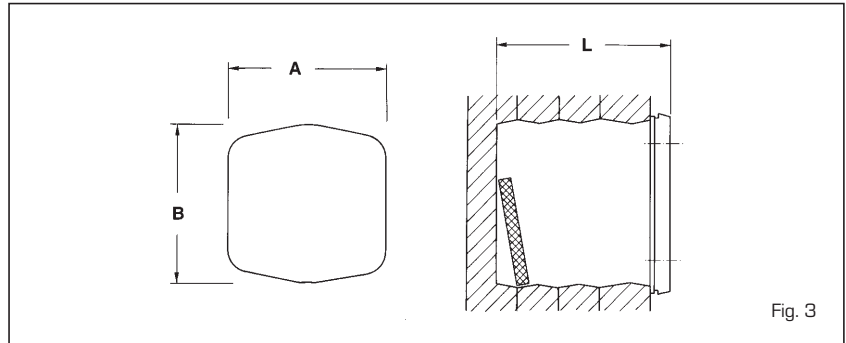

Fig. 3

"1R OF"	6	7	8	9	10
A mm	310	310	310	310	310
B mm	310	310	310	310	310
L mm	448	524	600	676	752
Volume m <sup>3</sup>	0.038510	0.045129	0.051748	0.058367	0.064986

"2R OF/OF S/GT OF"	6	7	8	9	10	11	12	13	14	15
A mm	390	390	390	390	390	390	390	390	390	390
B mm	430	430	430	430	430	430	430	430	430	430
L mm	570	670	770	870	970	1.070	1.170	1.270	1.370	1.470
Volume m <sup>3</sup>	0.081690	0.096314	0.110938	0.125562	0.140186	0.154810	0.169434	0.184058	0.198682	0.213306

## 1.6 SOME BURNER BRANDS COMPATIBLE

In general, the oil burner that is compatible with the boiler should use full spray nozzles.

### 1.6.1 ECOFLAM gas-oil burners

Boiler	Model		Atomising angle	Boiler	Model		Atomising angle
	1 flame	2 flames			1 flame	2 flames	
1R6 OF	MINOR 8	-	60°	2R6÷8 OF	MAIOR P 15	MAIOR P 15 AB	60°
1R7 OF	MINOR 8	-	60°	2R9÷12 OF	MAIOR P 25	MAIOR P 25 AB	60°
1R8 OF	MINOR 12	-	60°	2R13-14 OF	MAIOR P 35	MAIOR P 35 AB	60°
1R9 OF	MINOR 12	-	60°	2R15 OF	-	MAIOR P 45 AB	60°

### 1.6.2 RIELLO gas-oil burners

Boiler	Model				Atomising angle
	Gulliver	R. 40	REG	R2000	
1R6 OF	RG2 - RG2D	G10	-	G120	60°
1R7 OF	RG2 - RG2D	G10	-	G120	60°
1R8 OF	RG2 - RG2D	G10	-	G120	60°
1R9 OF	RG2 - RG2D - RG3 - RG3D	G10 - G20	-	G214 - G230D	60°
2R6 OF	RG3 - RG3D	G20	-	G214 - G230D	60°
2R7 OF	RG3 - RG3D	G20	-	G214 - G230D	60°
2R8 OF	RG3 - RG3D	G20	-	G214 - G230D	60°
2R9 OF	RG3 - RG3D	G20 - G20D	-	G214 - G230D	60°
2R10 OF	RG4S - RG4D - RG5D	G20 - G20D	-	-	60°
2R11 OF	RG4S - RG4D - RG5D	G20 - G20D	-	-	60°
2R12 OF	RL28/1 - RL28/2 - RG5D	-	-	-	60°
2R13 OF	RL28/1 - RL28/2 - RG5D	-	-	-	60°
2R14 OF	RL28/1 - RL28/2 - RG5D	-	-	-	60°
2R15 OF	RL28/1 - RL28/2 - RG5D	-	-	-	60°

### 1.6.3 F.B.R. gas-oil burners

Boiler	Model	Atomising angle	Boiler	Model	Atomising angle
1R6÷8 OF	G2 2001	60°	2R8 OF	FG 14 TC	60°
1R9 - 2R6 OF	G2 MAXI	60°	2R9÷13 OF	G 20 TC	60°
2R7 OF	FG 14 TC	60°	2R14-15 OF	G 30/2 TC	60° - 45°

## 1.6.4 SIME gas-oil burners

Boiler	Model	Atomising angle
1R 10 OF	MACK 7	60°

Boiler	Model	Atomising angle
--------	-------	-----------------

## 1.6.5 RIELLO gas burners

Boiler	Model	Output (kW)		Electrical data	Gas type
		1°stage	2°stage		
1R 6÷9 OF	GS10	42÷116	-	230V ±10% ~ 50Hz	G20/25 - G30/31
1R 10 OF	FS10	42÷116	-	230V ±10% ~ 50Hz	G20/25 - G30/31
2R 6 OF	GS10	42÷116	-	230V ±10% ~ 50Hz	G20/25 - G30/31
2R 7÷8 OF	BS 3	65÷189	-	230V ±10% ~ 50Hz	G20/25 - G30/31
2R 9÷11 OF	BS 4	110÷246	-	230V ±10% ~ 50Hz	G20/25 - G30/31
2R 8÷15 OF	RS 28	81	163-325	230V ±10% ~ 50Hz	G20/25 - G30/31
2R 8÷15 OF	RS 28/1	163÷349	-	230V ±10% ~ 50Hz	G20/25 - G30/31

## 1.6.6 Burner flange

The dimensions of the diesel burner anchorage flange are given in fig. 4.

	A	B	C
	mm	mm	∅
1R 6 OF	110	150	M8
1R 7÷10 OF	130	170	M8
2R 6-7 OF	130	170	M8
2R 8÷15 OF	160	190	M10
2R GT 6-7 OF	130	170	M8
2R GT 8÷15 OF	160	190	M10

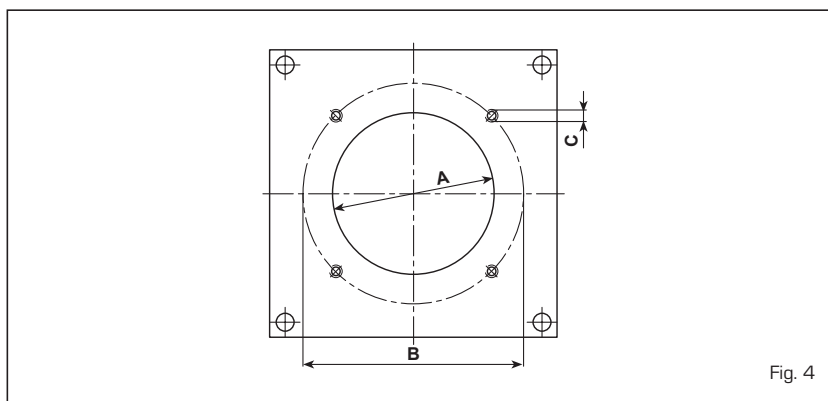

Fig. 4

# 2 INSTALLATION

## 2.1 BOILER ROOM

The boiler room should feature all the characteristics required by standards governing liquid fuel heating systems.

## 2.2 BOILER ROOM DIMENSIONS

Position the boiler body on the foundation bed, which should be at least 10 cm high. The body should rest on a surface allowing shifting, possibly by means of sheet metal.

Leave a clearance between the boiler and the wall of at least 0.60 m, and between the top of the casing and the ceiling of 1 m (0.50 m in the case of boilers with incorporated D.H.W. tank). The ceiling height of the boiler room should be less than 2.5 m.

## 2.3 CONNECTING UP SYSTEM

When connecting up the water supply to the boiler, make sure that the specifications given in fig. 1 are observed. All connecting unions should be easy to disconnect by means of tightening

rings. A closed expansion tank system must be used.

### 2.3.1 Filling the water system

**Before connecting the boiler, thoroughly flush the system to eliminate scale which could damage the appliance.**

Filling must be done slowly so as to allow any air bubbles to be bled off through the air valves. In closed-circuit heating systems, the cold water filling pressure and the pre-charging pressure of the expansion vessel should be no less than or equal to the height of the water head of the installation (e.g. for water head of 5 metres, the vessel pre-charging pressure and installation filling pressure should be at least 0.5 bar).

### 2.3.2 Water system characteristics

Water supplying the heating circuit must be treated in accordance with UNI-CTI 8065 standards. It is absolutely essential to treat water

in the heating system in the following cases:

- for extensive systems (with high contents of water);
- frequent addition of water into the system;
- should it be necessary to empty the system either partially or totally.

## 2.4 CONNECTING UP FLUE

The flue is of fundamental importance for the proper operation of the boiler; if not installed in compliance with the standards, starting the boiler will be difficult and there will be a consequent formation of soot, condensate and encrustation.

The flue used to expel combustion products into the atmosphere must meet the following requirements:

- be constructed with waterproof materials, and resistant to smoke temperature and condensate;
- be of adequate mechanical resilience and of low heat conductivity;
- be perfectly sealed to prevent cooling of the flue itself;
- be as vertical as possible; the termi-

nal section of the flue must be fitted with a static exhaust device that ensures constant and efficient extraction of products generated by combustion;

- to prevent the wind from creating pressure zones around the chimney top greater than the uplift force of combustion gases, the exhaust outlet should be at least 0.4 m higher than structures adjacent to the stack (including the roof top) within 8 m;
- have a diameter that is not inferior to that of the boiler union: square or rectangular-section flues should have an internal section 10% greater than that of the boiler union;
- the useful section of the flue must conform to the following formula:

$$S = K \frac{P}{\sqrt{H}}$$

S resulting section in cm<sup>2</sup>

K reduction coefficient for liquid fuels:

- 0.045 for firewood
- 0.030 for coal
- 0.024 for light oil
- 0.016 for gas

P boiler input in kcal/h

H height of flue in metres, measured from the flame axis to the top of the flue reduced by:

- 0.50 m for each change of direction of the connection union between boiler and flue;
- 1.00 m for each metre of union itself.

## 2.5 BOILER BODY ASSEMBLY

The boilers "2R OF S" are supplied with the dismantled cast iron body. For assembly, proceed as follows:

- remove the tie-rods from the boiler body and also the two upper front and lower panels;
- prepare the sections, cleaning the seats of the tapered nipples with solvent;
- insert the bead of putty (fig. 5) in the groove provided for fume tightness, pressing lightly;
- prepare one of the two intermediate sections. After cleaning and lubricating them with boiled linseed oil, insert the tapered nipples (fig. 6);
- prepare the head, proceeding as above, and bring it up to the intermediate section. Add only one section at a time;
- assemble the sections, using the tools provided consisting of a pair of

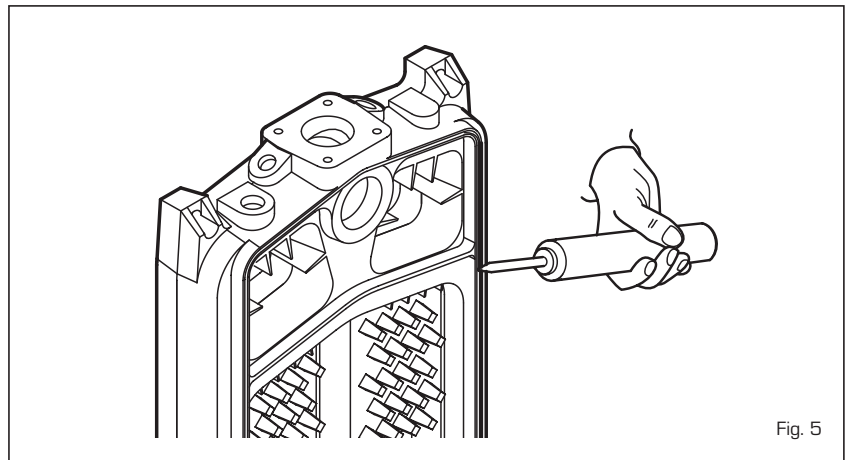

Fig. 5

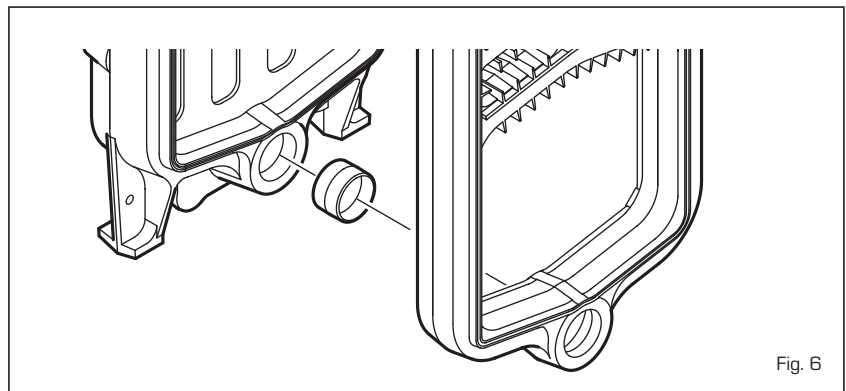

Fig. 6

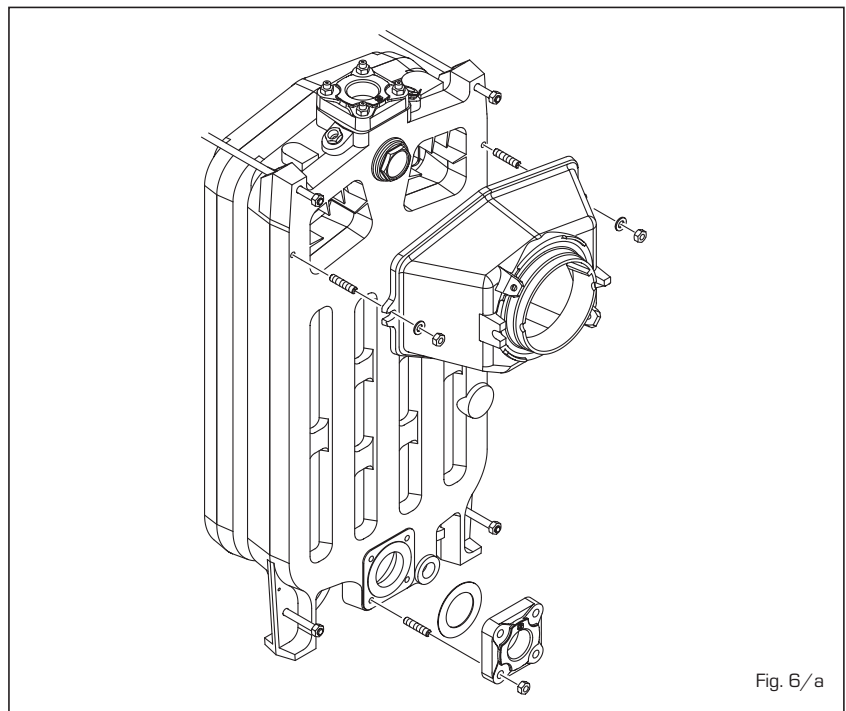

Fig. 6/a

staybolts for assembly with the corresponding accessories (code 6050900 - fig. 7), exerting pressure simultaneously on the top hub and on the bottom hub. If, during this operation, the sections were to slot together in such a way as not to be

even and parallel, slide a chisel in the tighter side and, by applying a little force, bring the two pieces together so that they are parallel.

The sections can be considered properly joined together when their outer edges come into contact;

- insert the bead of putty in the groove of the section that has just been assembled, and then proceed to joining up the other sections until the body is completed.
- replace the tie-rods in their original position;
- replace the two lower front and upper panels;
- install the smoke chamber and the flange as in figure 6/a.

**NOTE:** before proceeding to connect the system, test the boiler block with a water pressure of 7.5 bar and fill in the "testing certificate" completely.

## 2.6 FITTING THE CASING

The casing and the control panel are supplied in separate cardboard packa-

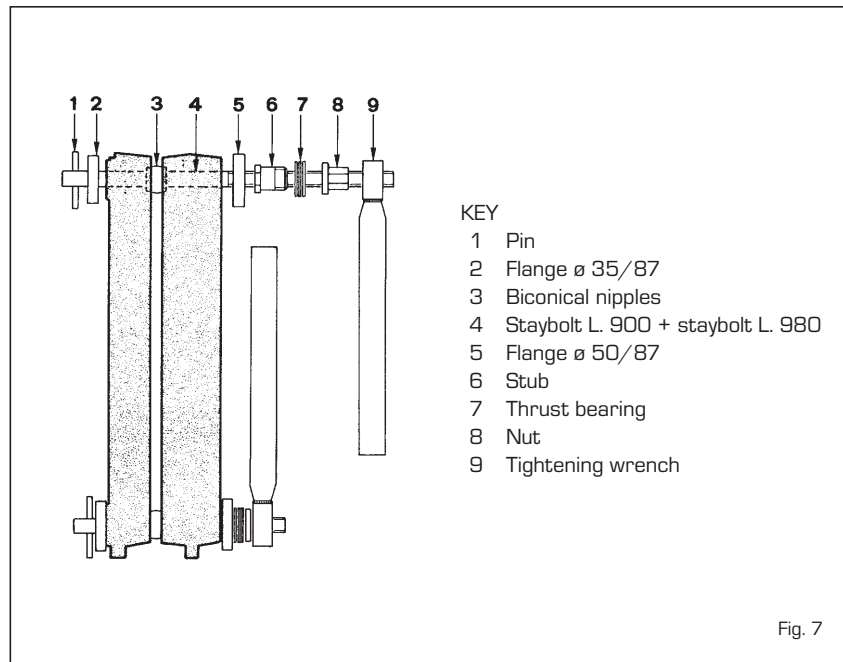

Fig. 7

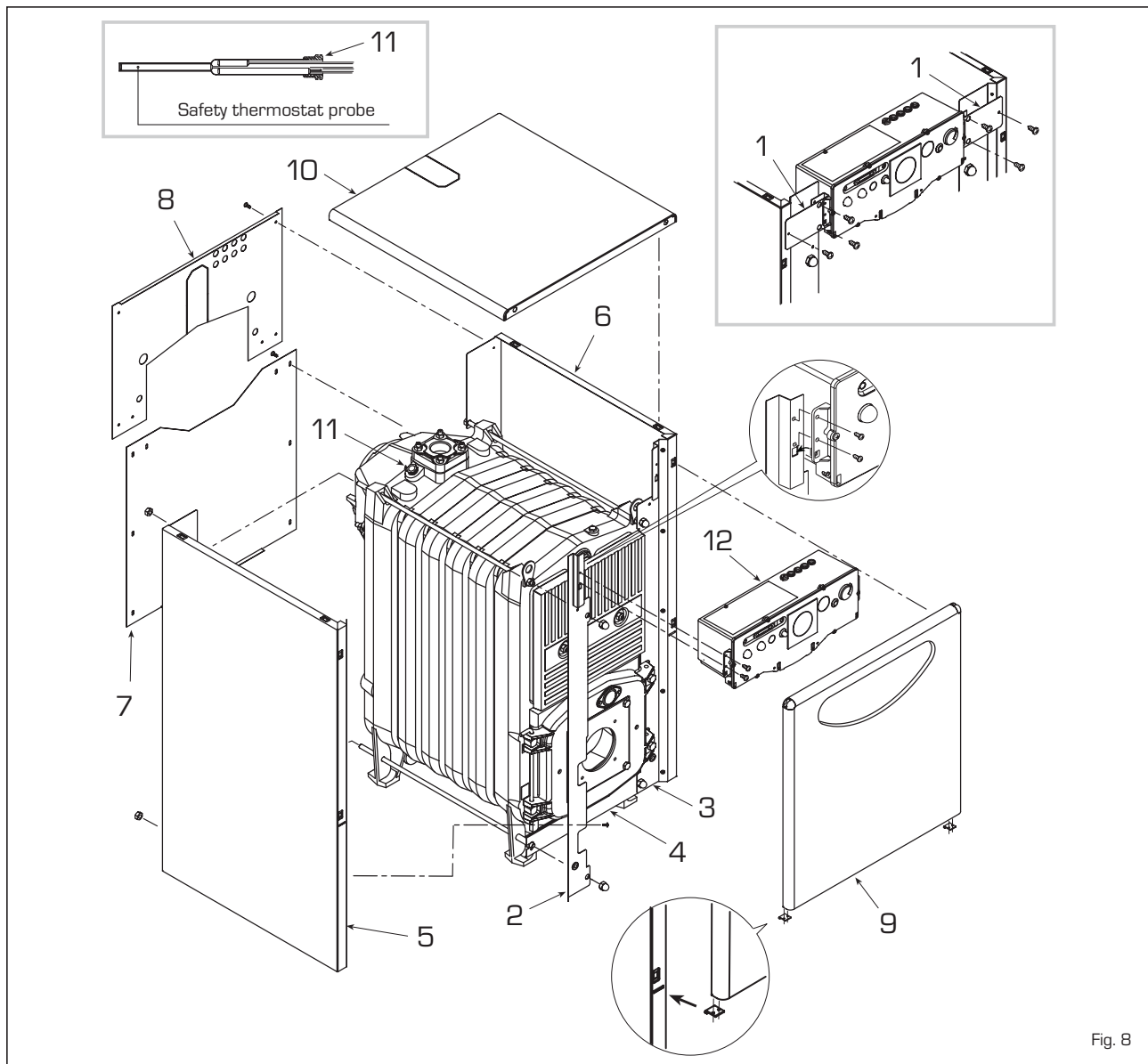

Fig. 8



ges. The housing package also contains the boiler documents and the glass wool for insulating the cast iron body. To fit the casing, proceed as follows (fig. 8):

- insert the front crosspiece (4) into the lower tie-rods;
- fix the left front side angle bar (2) and the right front side angle bar (3) to the tie-rods of the boiler body, blocking them with the four blind nuts provided;
- insulate the cast iron body with the glass wool provided;
- fix the side parts (5) and (6) to the angle bars using the ten self-tapping screws provided, and secure them at the back with the nuts placed on the tie rods;
- assemble the lower rear panel (7) with the eight self-tapping screws provided;
- assemble the upper rear panel (8) with the six self-tapping screws provided;
- fix the control panel (12) to the angle bars using the four screws provided. For vers. "2R OF/OF S/ GT OF", fix the left bracket (1) using three self-tapping screws and the right bracket (1), before installing the control panel, to the side parts and angle bars;
- unwind the capillary tubes of the two

thermostats and thermometer by inserting their sensors inside the sheath (11), securing the assembly in position using the capillary tube retaining spring provided;

- complete assembly by fixing the cover (10) and the front panel (9) to the side parts.

**NOTE: Remove the "Testing Certificate" from inside the combustion chamber and keep together with the instructions manual.**

## 2.7 ELECTRICAL CONNECTION (figg. 9 - 9/a)

The boiler is fitted with an electricity cable, and requires a single-phase power supply of 230V - 50Hz through the main switch protected by fuses. The room thermostat (required for enhanced room temperature control) must be connected to the terminals 4-5 after removing the link. Connect the burner cable supplied.

**NOTE: Device must be connected to an efficient earthing system. SIME declines all responsibility for injury caused to persons due to failure to earth the boiler.**

**Always turn off the power supply before doing any work on the electrical panel.**

## 2.8 RVA 43.222 CLIMAT CONTROLLER

All functions of the "2R GT OF" boiler may be controlled using the controller, optional code 8096303, which is supplied with an outdoor temperature probe (SE) and a boiler immersion probe (SC). The controller is installed in the control panel in place of the relating cover (fig. 11). The controller is to be connected to an additional series of low voltage connectors for connection of the room temperature control unit (the connectors are supplied in a bag inside the control panel). The probe bulb of the external hot water tank, if any, (SS) code 6277110, must be inserted in the hot water tank sheath, while the bulb of the boiler probe (SC) must be inserted in the boiler sheath.

When assembling the outdoor temperature probe, follow the instructions provided in the probe package. Refer to fig. 9/a for wiring instructions.

**IMPORTANT: To make sure that the unit works properly, set the boiler control thermostat as high as it will go.**

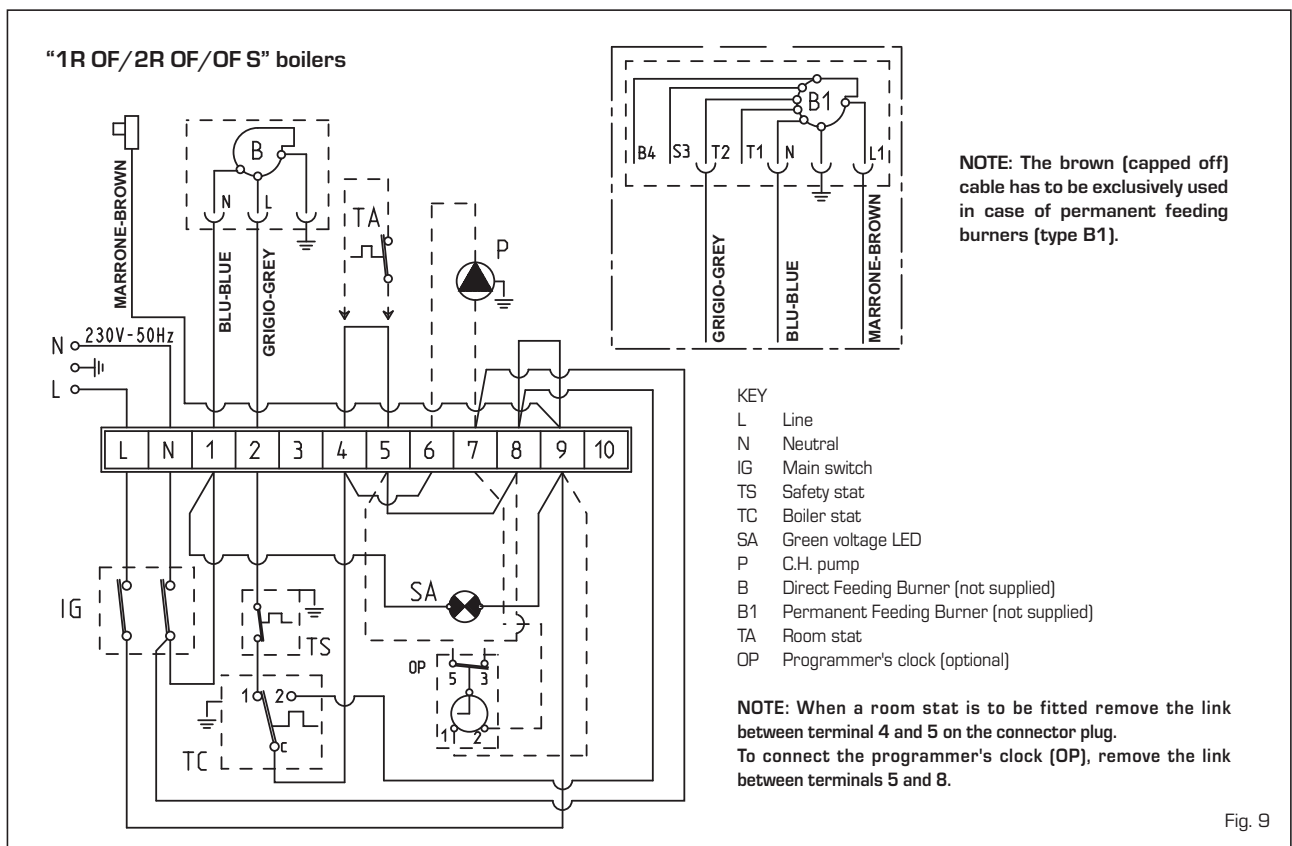
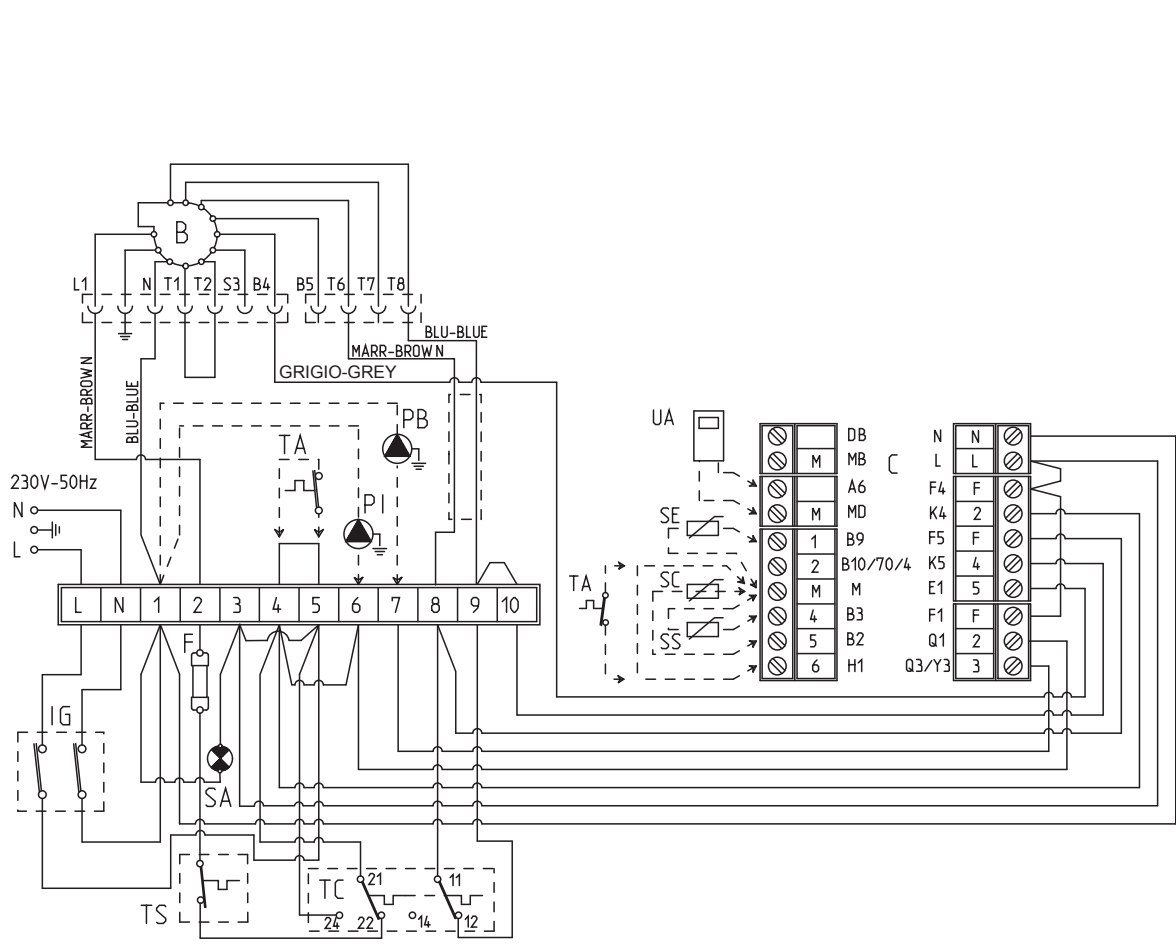

Fig. 9

"2R GT OF" boiler



KEY

- F Fuse (T 6.3A)
- IG Main switch
- TC Two-stage control thermostat
- TS Safety thermostat
- B Burner
- PI System pump
- PB Boiler pump
- C Connectors for RVA 43.222 controller (black - red - brown)
- TA Environment thermostat

- UA Type QAA70 room temperature control unit (optional)
- SE Outdoor temperature probe (optional)
- SC Type QAZ21 boiler probe (optional)
- SS Type QAZ21 hot water probe (optional)
- SA Green voltage LED

**NOTE: Connect the TA by removing the jumper from terminals 4-5. Connect up the RVA43.222 control device and remove the jumpers from terminal boards 4-5, 4-6, 9-10**

Fig. 9/a

### 3 USE AND MAINTENANCE

#### 3.1 COMMISSIONING THE BOILER

When commissioning the boiler it is recommended:

- to make sure that the system has been filled with water and adequately vented;
- to make sure that the flow and return valves are fully open;
- to make sure that flue and chimney are free from obstructions;
- to make sure that the electrical connections to the mains and the earthing are correct;
- to make sure that no flammable liquids or materials are near the boiler.

#### 3.2 LIGHTING AND OPERATION

##### 3.2.1 Lighting the boiler

To light the boiler proceed as follows

(fig. 11):

- switch on the main switch (1) and verify that the green LED (3) turns on to confirm the presence of voltage. The burner will start;
- turn the boiler stat knob (5) to the desired setting.

For best results, set the boiler stat knob to a temperature no lower than 60°C to prevent the formation of condensate.

The set temperature value can be checked on the thermometer (4).

##### 3.2.2 Safety stat

The safety stat with automatic reset calibration set at 100°C (2 fig. 11) trips, immediately turning off the burner when the boiler accidentally overheats.

To restore normal operations, wait until the temperature drops below the thermostat calibration setting.

##### 3.2.3 System filling

Periodically check the pressure values of the hydrometer mounted onto the system, when the system is cold, should range between 1 and 1.2 bar. If the pressure is less than 1 bar, reset the system.

##### 3.2.4 Turning OFF boiler

To temporarily turn off the boiler turn off the electricity supply by pressing the main switch (1 fig. 11).

The following operations must be carried out if the plant will not be in use for a lengthy period of time:

- position the main switch of the plant on off;
- turn the fuel and water taps of the central heating plant off;
- empty the central heating plant if there is danger of frost.

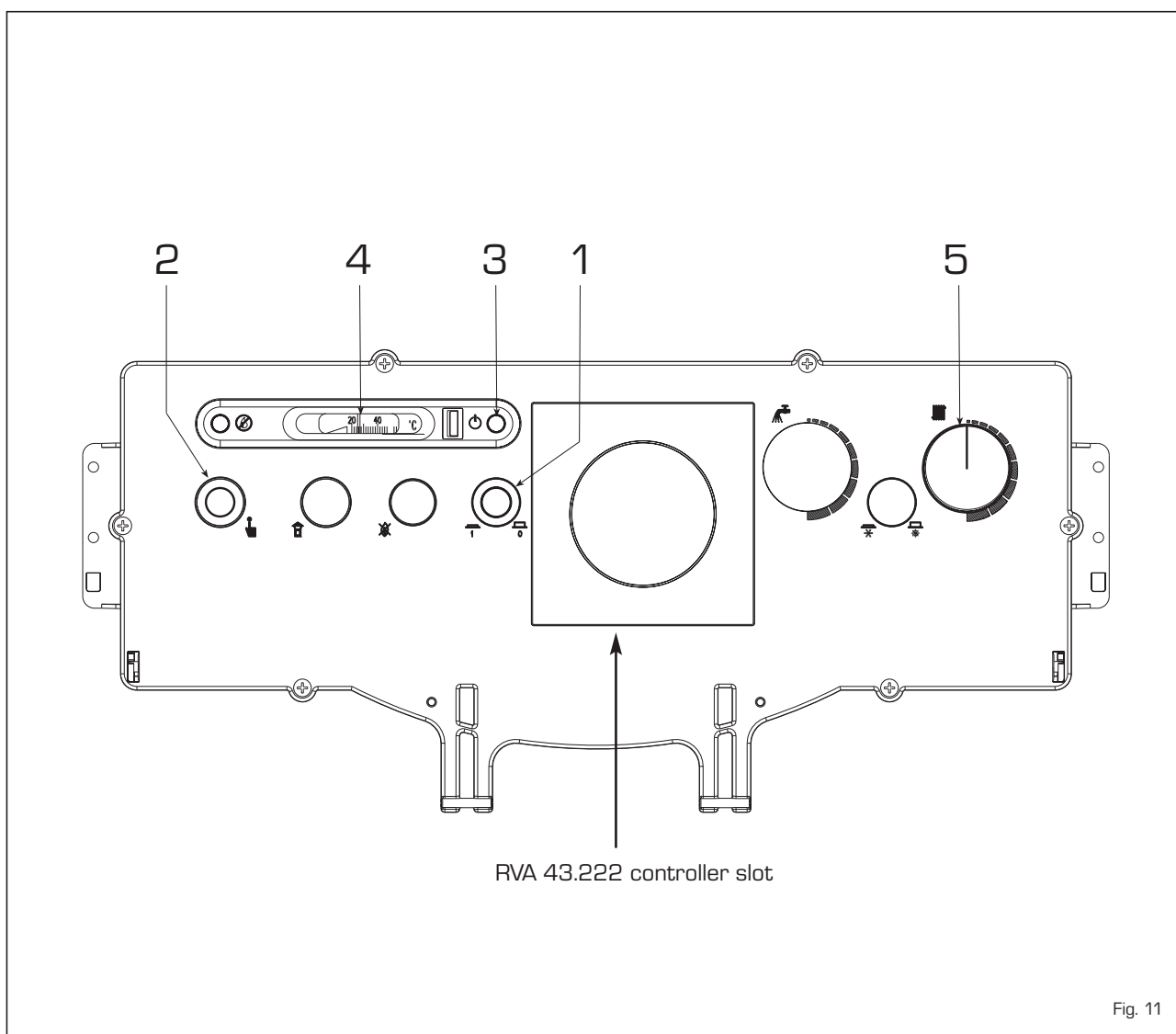

Fig. 11

### 3.3 CLEANING THE BOILER

(fig. 12)

The boiler body and flue should be cleaned at the end of each season. To clean the boiler, simply remove the burner-holding plate and the cleaning plate with their insulation and protection panels; this operation gives easy access to the three front pockets and

the combustion chamber. Before proceeding to clean the and "1R 6 OF - 2R 6 ÷ 9 OF/OF S/GT OF" models, the baffles must be removed. Once maintenance has been completed, reposition the baffles. Use the pig to clean the smoke pipes.

**NOTE: Preventive maintenance must be carried out by authorized technical staff.**

### 3.4 USER WARNINGS

When faults occur and/or the equipment does not operate correctly, turn it off, without attempting to make any repairs or take direct action.

For any operation only contact the authorised technical personnel in your area.

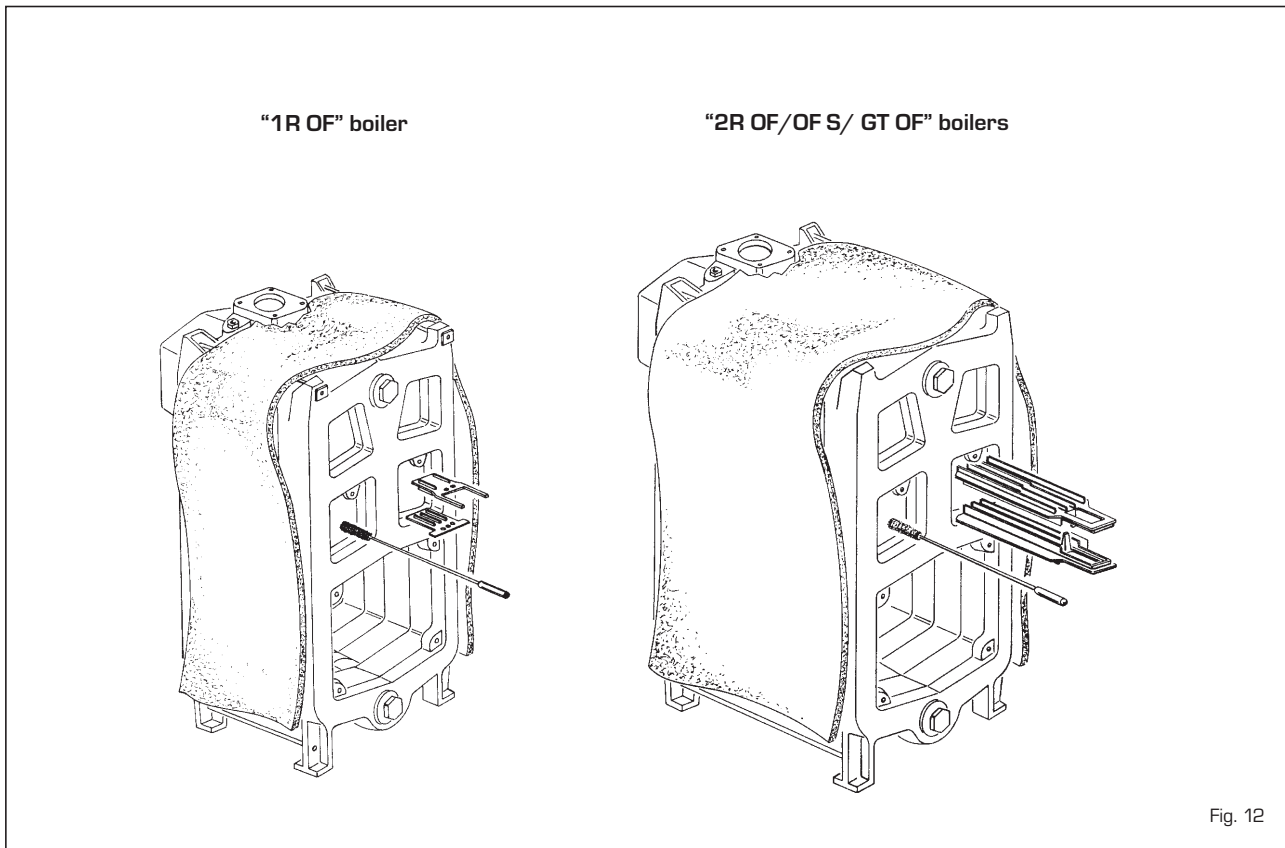

### 3.5 HOW TO USE THE "RVA 43.222"





To make the most of your "RVA 43.222" controller, follow the instructions provided below:

#### TO TURN ON THE HEATING

- Turn on the main switch.
- Set the correct hour of the day and the day of the week.
- Place in automatic mode with the button .

**ON**

#### TO SET THE HOUR

Select the line	Display	Set the regulation with the buttons
	1	 hour of the day
	2	 day of the week



#### HOW TO USE THE AUTOMATIC MODE

In the automatic mode the temperature of the room is regulated on the basis of the periods of heating chosen.

**Auto**

- Push the button .

**NOTE:** Select the heating periods according to one's daily requirements; in this way it is possible to significantly save on energy.

#### TO ACTIVATE CONTINUOUS HEATING

The continuous heating mode keeps the temperature of the room at the set level via the regulating knob.



- Push the "Continuous Operation" button .
- Regulate the room temperature with the regulating knob.

#### TO SET THE STANDBY MODE

(when the user is away for a long period of time)

The standby mode keeps the temperature of the room at the level of antifreeze protection.





- Push the "Standby mode" button .



#### MEANING OF THE SYMBOLS

On the display a few of the symbols indicate the current operating state. The appearance of a line under one of these symbols signals that the corresponding operating state is "active".



 Heating at the nominal temperature (regulating knob)

 Heating at reduced temperature (line .

 Heating at antifrost protection temperature (line .

**NOTE:** For further information on the symbols and the operating state refer to the detailed description of the heating plant.

#### TO VARY THE HOT WATER PRODUCTION

The production of hot water can be activated or deactivated by the push of a button.





- Push the button "Hot water" .

#### IF THE HOT WATER IS TOO HOT OR TOO COLD

Select the line	Display	Set the desired temperature
	13	 °C



#### IF THE ROOMS ARE TOO HOT OR TOO COLD

- Check that current operating state on the display.
- In the case of **nominal temperature** :  
Increase or reduce the temperature of the room with the regulating knob.
- In the case of **reduced temperature** .



Select the line	Display	Change the temperature with the buttons
	14	 °C



















**NOTE:** After each regulation wait at least two hours for the new temperature to expand through the room.

#### TO CHANGE THE HEATING PERIODS

Select the line	Display	Pre-select the weekly block or the single day
	5	 1-7 = week 1 = Lu/7 = Do



With reference to the day chosen set the changes as following:

Period requested	Push button	Display	Set hour	For °C
Period 1	Start 	6		
	End 	7		
Period 2	Start 	8		
	End 	9		
Period 3	Start 	10		
	End 	11		

**NOTE:** The heating periods automatically repeat on a weekly basis.

To this end select the automatic mode.

It is possible to reset the standard programme on line 23 by pushing the buttons + and - at the same time.

#### IF THE HEATING DOES NOT WORK PROPERLY

- Refer to the detailed documentation on the heating system, following the fault finding instructions.



#### TO MEASURE GAS COMBUSTION

- Push the "chimneysweep" button .
- The heating will work according to the level requested.



#### HOW TO SAVE ENERGY WITHOUT FOREGOING ON COMFORT

- A temperature of around 21°C is advised in the rooms that are used. Every degree above this will increase heating costs by 6-7%.
- Aerate the rooms only for a brief period, opening the windows completely.
- In the rooms that are not used place the regulating valve in the antifreeze position.
- Leave the space in front of the radiators free from obstructions (remove furniture, curtains...).
- Close windows and blinds to reduce dispersion of heat.



## DICHIARAZIONE DI CONFORMITA' CALDAIE A COMBUSTIBILE LIQUIDO

La **FONDERIE SIME SpA**, con riferimento all'art. 5 DPR n°447 del 6/12/1991 "Regolamento di attuazione della legge 5 marzo 1990 n°46", dichiara che le proprie caldaie a combustibile liquido serie:

**AR - ARB**

**1R - 1R OF - 2R - 2R OF/OF S/GT OF \***

**1R SUPERIOR - 2R SUPERIOR \***

**SOLO - SOLO OF - SOLO BF TS - SOLO BF TSE**

**DUETTO - DUETTO OFi/BFi - DUETTO BF TS - DUETTO BF TSE**

**AQUA - AQUA OF/BF - AQUA BF TS - AQUA INOX BF TS - AQUA INOX BF TSE**

**RONDO' - RONDO' B**

**ESTELLE - ESTELLE OF - ESTELLE B INOX**

**ESTELLE BF TS/OF TS - ESTELLE B INOX BF TS**

**ESTELLE HE - ESTELLE HE B INOX**

sono complete di tutti gli organi di sicurezza e di controllo previsti dalle norme vigenti in materia e rispondono, per caratteristiche tecniche e funzionali, alle prescrizioni delle norme:

**UNI 7936** (dicembre 1979), FA130-84, FA168-87

**EN 303-1994**

**DIRETTIVA RENDIMENTI 92/42 CE.**

**D.M. 174 del 06-04-2004** materiali a contatto con acqua destinata al consumo umano.

La ghisa grigia utilizzata è del tipo EN-GJL 150 secondo la norma europea **UNI EN 1561**.

Il sistema qualità aziendale è certificato secondo la norma **UNI EN ISO 9001: 2000**.

Le caldaie a gasolio e gas (\*) sono conformi alla:

**DIRETTIVA GAS 2009/142/CE** per la conformità CE di tipo

**DIRETTIVA BASSA TENSIONE 2006/95/CE**

**DIRETTIVA COMPATIBILITÀ ELETTROMAGNETICA 2004/108/CE**

Legnago, 30 gennaio 2013

Il Direttore Tecnico  
**FRANCO MACCHI**











Fonderie Sime S.p.A - Via Garbo, 27 - 37045 Legnago (Vr)  
Tel. + 39 0442 631111 - Fax +39 0442 631292 - [www.sime.it](http://www.sime.it)